

# ePAPER 2.0" - 172X72 PIXEL

**INKL. KONTROLLER SSD1606 MIT SPI**

*ab 1 Stück lieferbar !*



Maße:  
59,2 x 29,2 mm

## TECHNISCHE DATEN

- \* KONTRASTREICHSTE ePAPER LCD ANZEIGE
- \* WEITER BLINKWINKELBEREICH
- \* ELEKTROPHORETISCH-AKTIV-MATRIX DISPLAY (ePAPER) 2" MIT 172x72 PIXEL
- \* KONTROLLER SSD1606 MIT SPI 4-DRAHT ODER 3-DRAHT (9-BIT) INTERFACE
- \* SPANNUNGSVERSORGUNG +3,3V SINGLE SUPPLY
- \* KEINE ZUS. SPANNUNGEN ERFORDERLICH
- \* BETRIEBSTEMPERATURBEREICH 0°...+50°C (LAGERTEMPERATUR -25°..+75°C)
- \* STANDBY-POWER 0W (INHALT LESBAR)
- \* LEISTUNGS-AUFNAHME BEI INHALTWECHSEL ca. 40 mW (~3 Sek. Bildschirmupdate)
- \* ON-CHIP DISPLAY RAM
- \* ON-CHIP BOOSTER UND REGLER FÜR GATE UND SOURCE SPANNUNGEN
- \* 4 GRAUSTUFEN - SCHWARZ, DUNKELGRAU, HELLGRAU, WEISS

## BESTELLBEZEICHNUNG

ePAPER DISPLAY 2" 172X72  
INTELLIGENTES 2" E-PAPER MIT RS-232, I<sup>2</sup>C, SPI, FONTS  
EVALUATION KIT INKL. 2" EA ELABEL20-A UND USB-PROGRAMMER

**EA EPA20-A**  
**EA ELABEL20-A**  
**EA EVALEPA20-A**

## ZUBEHÖR

ZIFF-STECKER, 24 PINS, TOP KONTAKT

**EA WF050-24T**

## APPLIKATIONSBEISPIEL

Im folgenden sehen Sie die Standardbeschaltung (SPI 4-Draht, 8 Bit) des EA EPA20-A.

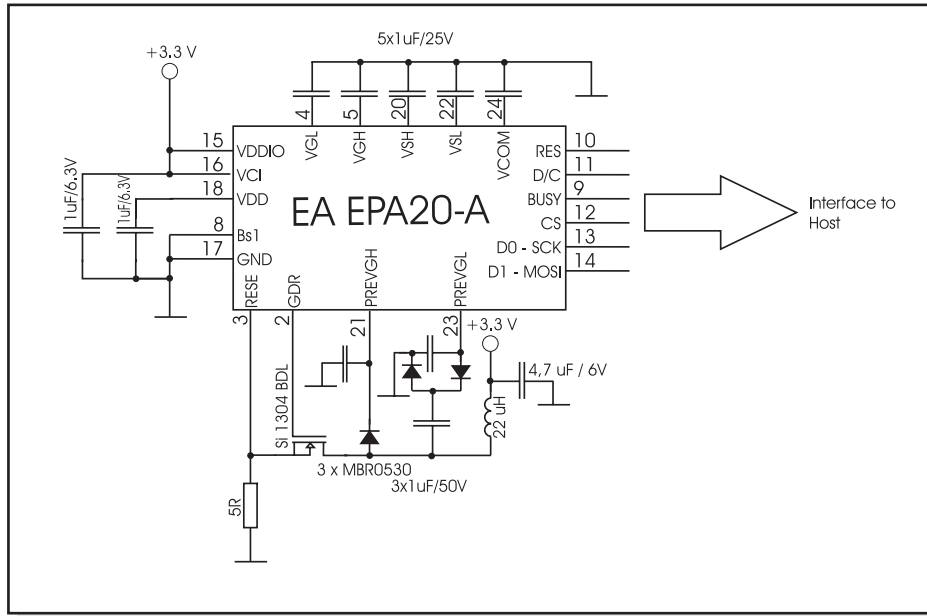

## INITIALISIERUNGSBEISPIEL

```
const unsigned char lut_data [] =
{
    0x82, 0x00, 0x00, 0x00, 0xAA, 0x00, 0x00, 0x00, 0xAA,
    0xAA, 0x00, 0x00, 0xAA, 0xAA, 0xAA, 0x00, 0x55, 0xAA,
    0xAA, 0x00, 0x55, 0x55, 0x55, 0x55, 0xAA, 0xAA, 0xAA,
    0xAA, 0x55, 0x55, 0x55, 0x55, 0xAA, 0xAA, 0xAA, 0xAA,
    0x15, 0x15, 0x15, 0x15, 0x05, 0x05, 0x05, 0x05, 0x01,
    0x01, 0x01, 0x01, 0x00, 0x00, 0x00, 0x00, 0x00, 0x00,
    0x00, 0x00, 0x00, 0x00, 0x00, 0x00, 0x00, 0x00, 0x00,
    0x00, 0x00, 0x00, 0x00, 0x00, 0x00, 0x00, 0x00, 0x00,
    0x00, 0x00, 0x00, 0x00, 0x00, 0x00, 0x00, 0x00, 0x41,
    0x45, 0xF1, 0xFF, 0x5F, 0x55, 0x01, 0x00, 0x00, 0x00
};
```

```
void SPI_out (unsigned char data)
{
    uchar count;
    CS=0;
    for(count=0;count<8;count++)
    {
        if (data&0x80)
            SDIN=1;
        else
            SDIN=0;
        SCLK=1;
        data<<=1;
        SCLK=0;
    }
    CS=1;
}
```

```
void writcmd(char data)
{
    DC=0;
    SPI_out (data);
}
```

```
void writedata(char data)
{
    DC=1;
    SPI_out (data);
}
```

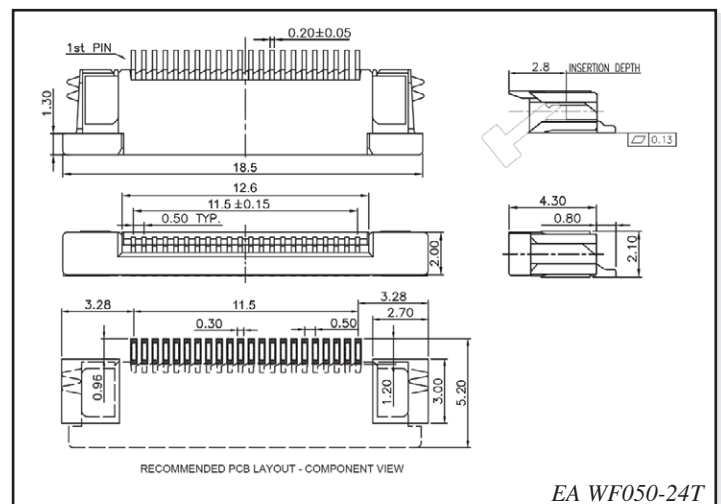

```
void init(void)
{
    unsigned char i;

    CS=1;           //perform reset CS idle=1
    SCLK=0;        //SCLK idle=0
    RST=1;
    delaysms(1);
    RST=0;
    delaysms(2);
    RST=1;
    delaysms(3);

    writecmd(0x10); //do not enter deep sleep mode
    writedata(0x00);

    writecmd(0x11); //data entry mode setting,0x01,Y decrement,X increment
    writedata(0x01);
    writecmd(0x44); //set RAM X-address start/end position
    writedata(0x00); //RAM X -address start at 00H
    writedata(0x11); //RAM X-address end at 11H->(17D),that is (17+1*4=72)start/end
                    //position
    writedata(0xAB); //RAM Y-address start at ABH->(171D)
    writedata(0x00); //RAM Y-address end at 00H
    writecmd(0x4E); //set RAM x address count to 0;
    writedata(0x00);
    writecmd(0x4F); //set RAM Y address count to 172->0;
    writedata(0xAB);

    writecmd(0xF0); //booster feedback selection,0x1F->internal feedback is used
    writedata(0x1F); //0x83
    writecmd(0x21); //bypass the RAM data into the display,enable pass
    writedata(0x03);
    writecmd(0x2C); //write VCOM register
    writedata(0xA0);
    writecmd(0x3C); //board waveform, board voltage
    writedata(0x63);
    writecmd(0x22); //enable sequence, CLK->CP->
    writedata(0xC4);

    writecmd(0x32); //write LUT register
    for(i=0;i<90;i++)
        writedata(lut_data[i]);
}

void fill_display(uchar dat) //0xFF=white, 0x00=black, 0x55=gray 1, 0xAA=gray 2
{
    unsigned int i;

    writecmd(0x24); //data write into RAM after this command

    for(i=0;i<3096;i++) //3096 = 172x72/8x2, (2-Bit per dot)
    {
        writedata(dat);
    }
    writecmd(0x20);

    //Booster diable
    writecmd(0x22); //display updata sequence option ,in page 33
    writedata(0x02);
    writecmd(0x20);
}
}
```

Weitere Details über das Kommandoset und die elektrischen Spezifikationen finden Sie im  
Kontrollerdatenblatt des SSD1606 unter:

[http://www.lcd-module.de/eng/pdf/zubehoer/ssd1606\\_1\\_1.pdf](http://www.lcd-module.de/eng/pdf/zubehoer/ssd1606_1_1.pdf)

ABMESSUNGEN

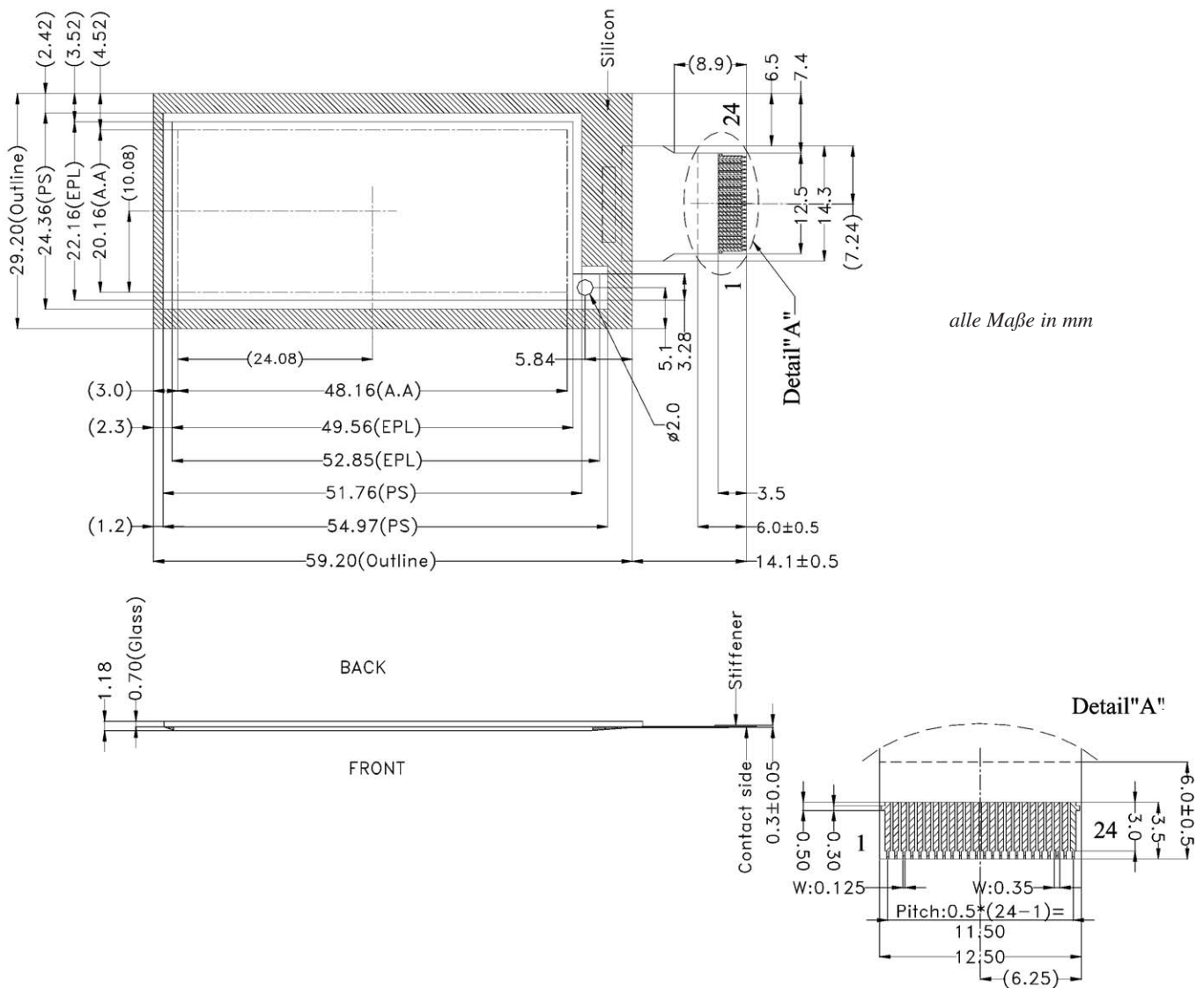

alle Maße in mm

Pin	Symbol	Function	Pin	Symbol	Function
1	DNC	do not connect	13	D0	SPI-Clock (SCK)
2	GDR	Gate drive control	14	D1	SPI-Data (MOSI)
3	RESE	current sense input	15	VDDIO	Power for I/O logic pins
4	VGL	negative gate driving voltage	16	VCI	Power for display driver chip
5	VGH	positive gate driving voltage	17	GND	Ground
6	TSCL	°C digital temp. sensor clock	18	VDD	Power supply
7	TSDA	°C digital temp. sensor data	19	VPP	Power for OTP programming
8	BS1	L: 4-wire SPI (8 bit) H: 3-wire SPI (9 bit)	20	VSH	positive source driving voltage
9	BUSY	H: Busy state output pin	21	PREVGH	power supply for VGH and VSH
10	RES	L: Reset	22	VSL	negative source driving voltage
11	D/C	H: Data L: Command	23	PREVGL	Power supply for VCOM, VGL, VSL
12	CS	L: Chip select	24	VCOM	VCOM driving voltage



Hinweis:

- Die Oberfläche des Displays ist durch eine selbstklebende Folie geschützt. Bitte nach der Verarbeitung entfernen.
- Das Display besteht aus dünnem Glas: Achtung, zerbrechlich!