

EA eDIP: Touch Panel with I²C, RS-232 and SPI

- Touch Panel incl. Controller
- RS-232 + I²C-Bus + SPI
- USB + RS-485 via External Circuit
- Character sets & Graphic functions
- 128x64 .. 320x240 Monochrome
- Colored TFT 3.2" ~ 7"
- Single Supply +5V (some +3.3V)
- T_{Op.} -20..+70°C



How to work with Intelligent Graphic Displays



No more „pixel programming“

but, instead, efficient operation with extensive drawing functions and fonts. The advantages are obvious:

- * no time-consuming graphics programming
- * drastically reduced time-to-market
- * tested functions validated thousands of times
- * unparalleled flexibility thanks to powerful commands
- * extremely compact construction
- * a clear price advantage compared to individualized solutions



Powerful commands

such as the touch key with menu function, clipboard, bargraph, centered strings... You can therefore create the screen layout you want with just a few, easily understood commands. All the commands are based on coordinate specifications and can therefore be applied and moved to the nearest pixel. There is a built-in self-test facility for demonstration purposes and initial testing.

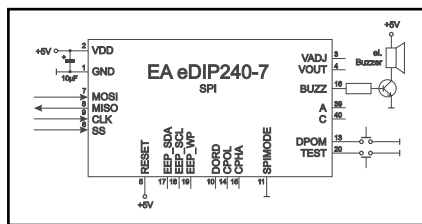

3 different interfaces: RS-232, I²C, SPI

There is something to match every system: depending on the configuration, the connection can be established via an RS-232 (CMOS level), SPI or I²C bus interface.

USB, RS-485 interface

With a simple external IC (e.g. FT232R or SN75176) it is easy to adapt to some more interfaces. Application notes are available.

Touch Panel

Optionally, we can also supply this display with an analog touch panel which can be used for all types of input. An integrated touch controller is responsible for representing and labelling the keys as well as for their interpretation. What is more, the shape, size and number of the keys can be modified whenever required at runtime. This permits a clear, well-organized screen layout that helps eliminate operating errors. Device adaptations for foreign countries and languages are simple to implement even in tiny runs. This also includes e.g. Cyrillic, Hebrew, Arabic.

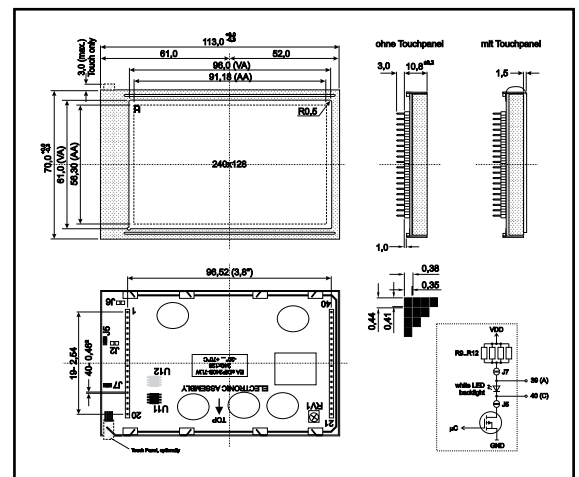
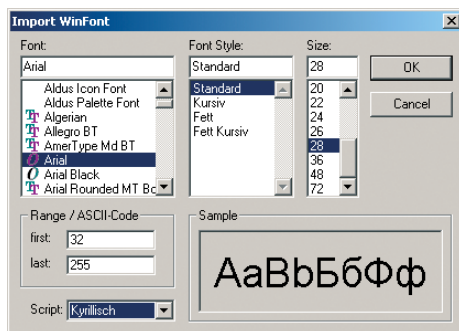

Character sets

7 built-in fonts in different sizes. All the character sets can be enlarged up to 4 times to their original size. A command allows you to rotate them by 90° for vertical presentation. All character sets can be re-defined by a powerful and free FontEditor tool. Individual character sets may be added easily.



Evaluation kit for Windows with USB interface

For a quick and easy start an evaluation kit is available. This includes a display with touch panel, an USB test board, editor and compiler. It provides lots of interfaces like RS-232 (5V), RS-232 (±12V), RS-485, SPI, I²C, and USB. Some push buttons allow to emulate the inputs, some LED do show the status for the output lines.

