

# CONTROL UNIT

## 320x240 WITH INTELLIGENCE

**WORLD FIRST!**



Dimensions:  
138x105x10mm

### TECHNICAL DATA

- \* LCD GRAPHIC DISPLAY WITH A RANGE OF GRAPHIC FUNCTIONS
- \* 8 BUILT-IN FONTS
- \* FONT ZOOM FROM approx. 2mm TO approx. 80mm, also rotated by 90°
- \* 3 DIFFERENT INTERFACE ONBOARD: RS-232, I<sup>2</sup>C-BUS OR SPI-BUS
- \* 320x240 DOTS WITH LED BACKLIGHT BLUE NEGATIVE OR BLACK&WHITE POSITIVE, FSTN TECHNOLOGY AND AMBER
- \* POWER SUPPLY +5V@ typ. 50mA / 240mA (WITHOUT / WITH LED BACKLIGHT)
- \* POSITIONING **ACCURATE TO THE PIXEL** WITH ALL FUNCTIONS
- \* DRAW LINE, DOT, AREA, AND/OR/EXOR, BARGRAPH...
- \* CLIPBOARD FUNCTION, PULL-DOWN MENU
- \* UP TO 16 PAGES á 256 PICTURES INTERNALLY STORED
- \* UP TO 16 PAGES á 768 MACROS PROGRAMMABLE (80kB ON-BOARD FLASH)
- \* MIX TEXT AND GRAPHIC, FLASHING ATTRIBUTE: ON/OFF/ INVERT
- \* BACKLIGHT BRIGHTNESS PER SOFTWARE
- \* ANALOGUE TOUCH PANEL: VARIABLE GRID
- \* FREE DEFINABLE KEY AND SWITCH
- \* POWER-DOWN-MODE (TYP. 150µA) WITH WAKEUP BY TOUCH

### ORDERING CODES

320x240 DOTS, WHITE LED BACKLIGHT, BLUE NEGATIVE  
AS ABOVE, BUT WITH TOUCH PANEL

320x240 DOTS, WHITE LED BACKLIGHT, POSITIVE MODE, FSTN  
AS ABOVE, BUT WITH TOUCH PANEL

320x240 DOTS, AMBER LED BACKLIGHT, POSITIVE MODE, FSTN  
AS ABOVE, BUT WITH TOUCH PANEL

MOUNTING FRAME (ALUMINIUM), BLACK ANODIZED  
PROGRAMMER FOR USB INCL. CABLE, CD FOR WIN98/ME/2000/XP  
STARTER KIT, (1x EA eDIP320B-8LWTP + USB-PROGRAMMER + CD)

EA eDIP320B-8LW  
EA eDIP320B-8LWTP

EA eDIP320J-8LW  
EA eDIP320J-8LWTP

EA eDIP320J-8LA  
EA eDIP320J-8LATP

EA 0FP321-8SW  
EA 9778-1USB  
EA START-eDIP320

**ELECTRONIC  
ASSEMBLY**

making things easy

Documentation of revision				
Date	Type	Old	New	Reason / Description
9.11.2006	V1.0			1st. edition
3.4.2007	V1.1	bug fix: - corrupted character chain - bargraph return code fixed - single picture for touch keys		
9.6.2011	V1.2		changed specification of pull-up resistor (RESET pin)	Changed specification, because of product change notification (SC112002) of ATMEL.

**CONTENTS**

GENERAL ..... 3

ELECTRICAL SPECIFICATIONS ..... 4

RS-232 ..... 5

SPI ..... 6

I<sup>2</sup>C ..... 7

SOFTWARE PROTOCOL ..... 8 - 9

TOUCH PANEL ..... 10

TERMINAL MODE ..... 11

CHARACTER SETS ..... 12-13

COMMANDS/FUNCTIONS IN TABULAR FORMAT ..... 14 - 16

RESPONSES OF THE OPERATING PANEL ..... 17

COMMAND TRANSFER/PARAMETERS ..... 17

TOP VIEW, POWER DOWN ..... 18

MACRO PROGRAMMING ..... 19 - 21

MULTILINGUAL CAPABILITY, MACRO PAGES ..... 21

USB PROGRAMMING BOARD ..... 22

DIMENSIONS ..... 23 - 24

## GENERAL

The EA eDIP series of displays are the world's first displays with integrated intelligence. In addition to a variety of integrated fonts that can be used with pixel accuracy, they offer a whole range of sophisticated graphics functions.

The displays are ready for operation immediately with an operating voltage of 5V. They are controlled via one of the 3 integrated interfaces: RS-232, SPI or I<sup>2</sup>C. The displays are "programmed" by means of high-level language-type graphics commands. There is no longer any need for the time-consuming programming of character sets and graphics routines. The ease of use of this display with its touch panel dramatically reduces development times.

## HARDWARE

The display is designed to work at an operating voltage of +5V. Data transfer is either serial and asynchronous in RS-232 format or synchronous via the SPI or I<sup>2</sup>C specification. To improve data security, a simple protocol is used for all types of transfer.

## ANALOG TOUCH PANEL

All versions are also available with an integrated touch panel: You can make entries and menu or bar graph settings by touching the display. The labeling of the "keys" is flexible and can also be changed during runtime (different languages, icons). The drawing of the individual "keys" and the labeling is handled by the integrated software.

## LED ILLUMINATION: BLUE, WHITE, AMBER

All displays are equipped with modern, energy-saving LED illumination. Brightness can be varied 0~100% by command. While the black&white display (J-LW) and the amber one (J-LA) can also be read with the illumination switched off entirely, the blue-white display (B-LW) needs at least minimal illumination if it is to be read.

We recommend the black&white or amber version for use in direct sunlight. In all other cases we recommend the very high-contrast blue-white version.

In 24-hour operation, the illumination of the J-LW and B-LW types should be dimmed or switched off as often as possible to increase their lifetime. The amber version (J-LA) is also suitable for continuous use at 100% illumination (MTBF 100,000 hours).

## SOFTWARE

This display is programmed by means of commands, such as *Draw a rectangle from (0,0) to (64,15)*. No additional software or drivers are required. Strings and images can be placed with **pixel accuracy**. Flashing attributes can be assigned as often as you like. Text and graphics can be combined at any time. Up to 32 different character sets can be used. Each character set and the images can be zoomed from 2 to 8 times and rotated in 90° steps. With the largest character set, the words and numbers displayed will fill the screen.

## ACCESSORIES

### PROGRAMMER FOR INTERNAL DATA FLASH MEMORY

The display is shipped fully programmed and with all fonts. The additional programmer is thus generally not required.

However, if the internal character sets have to be changed or extended, or if images or macros have to be stored internally, the USB programmer EA 9778-1USB, which is available as an accessory, will burn the data/images you have created into the on-board data flash memory (80 kB) permanently. The programmer runs under Windows and is connected to the PC's USB interface. It is shipped with an interface cable and the installation software.

## SPEZIFICATION AND CHARACTERISTICS

Characteristics					
Value	Condition	min.	typ.	max.	Unit
Operating Temperature		-20		+70	°C
Storage Temperature		-30		+80	°C
Storage Humidity	< 40°C			90	%RH
Operating Voltage		4.5	5.0	5.5	V
Input Low Voltage		-0.5		0.2*VDD	V
Input High Voltage	Pin Reset only	0.9*VDD		VDD+0.5	V
Input High Voltage	except Reset	0.6*VDD		VDD+0.5	V
Input Leakage Current	Pin MOSI only			1	uA
Input Pull-up Resistor		20		50	kOhms
Reset Pull-up Resistor		65		85	kOhms
Output Low Voltage				0.7	V
Output High Voltage		4.0			V
Output Current				20	mA
Power Supply	White Backlight 100%		230		mA
	Amber Backlight 100%		190		mA
	Backlight off		50		mA
	Powerdown (see page 18)	5	150		µA

## OUTPUTS

The EA eDIP320 offers up to 8 outputs, which can be used to control LEDs, for example. The configuration pins used depend on the interface selected (RS232, SPI or I<sup>2</sup>C). The configuration pins (open drain with internal pullup) are then evaluated as 1=HIGH level.

Each output can be controlled by means of the 'ESC YW n1 n2' command. Current can only flow when the level is at L (open drain with internal pullup). Each output can supply a maximum of 10 mA. It is thus possible to connect an LED to an output directly. Higher currents can be connected by using an external transistor.

Assignment output <-> pin no.						
output	RS232/RS422		SPI		I2C	
	pin no.	symbol	pin no.	symbol	pin no.	symbol
OUT1	6	BAUD0	10	DORD	6	BA0
OUT2	7	BAUD1	12	OUT2	7	BA1
OUT3	8	BAUD2	13	WUP	8	SA0
OUT4	9	ADR0	14	CPOL	9	SA1
OUT5	13	WUP	15	CPHA	10	SA2
OUT6	14	ADR1	17	DPROT	11	BA2
OUT7	15	ADR2			13	WUP
OUT8	17	DPROT			17	DPROT

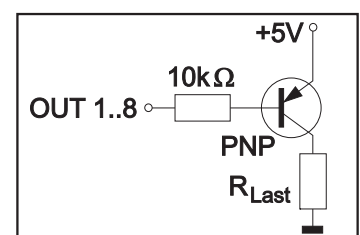
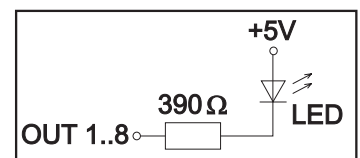

### RS-232 INTERFACE

If the display is wired as shown below, the RS-232 interface is selected. The pin assignment is specified in the table on the right.

The RxD and TxD lines lead 5V (CMOS level) to a microcontroller, for example, for direct connection.

If "genuine" RS-232 levels are required (e.g. for connection to a PC), an external level converter (e.g. MAX232) is required.

*Note:*

The pins BAUD 0 to 2, ADR 0 to 2, WUP, DPROT and TEST/SBUF have an internal pullup, which is why only the LO level (0=GND) is to be actively applied. These pins must be left open for a Hi level.

For RS232 operation (without addressing) the pins ADR 0 to ADR 2 must be left open.

On pin 20 (SBUF) the display indicates with a low level that data is ready to be retrieved from the internal send buffer. The line can be connected to an interrupt input of the host system, for example.

Pinout eDIP320-8: RS-232/RS-422 mode						
Pin	Symbol	In/Out	Function	Pin	Symbol	Function
1	GND	-	Ground Potential for logic (0V)	25	N.C.	not connected
2	VDD	-	Power supply for logic (+5V)	26	N.C.	not connected
3	VADJ	In	Operating voltage for LC driving (input)	27	N.C.	not connected
4	VOUT	Out	Output voltage for LC driving	28	N.C.	not connected
5	RESET	-	L: Reset	29	N.C.	not connected
6	BAUD0	In	Baud Rate 0	30	N.C.	not connected
7	BAUD1	In	Baud Rate 1	31	N.C.	not connected
8	BAUD2	In	Baud Rate 2	32	N.C.	not connected
9	ADR0	In	Address 0 for RS-485	33	N.C.	not connected
10	RxD	In	Receive Data	34	N.C.	not connected
11	TxD	Out	Transmit Data	35	N.C.	not connected
12	EN485	Out	Transmit Enable for RS-485 driver	36	N.C.	not connected
13	WUP	In	L: (Power-On) disable Power-On-Macro L: Wakeup from Powerdownmode	37	N.C.	not connected
14	ADR1	In	Address 1 for RS-485	38	N.C.	not connected
15	ADR2	In	Address 2 for RS-485	39	N.C.	not connected
16	BUZZ	Out	Buzzer output	40	N.C.	not connected
17	DPROT	In	L: Disable Smallprotokoll do not connect for normal operation	41	N.C.	not connected
18	DPWR	Out	L: Normal Operation H: Powerdownmode	42	N.C.	not connected
19	WP	In	L: Writeprotect for DataFlash	43	N.C.	not connected
20	TEST SBUF	IN Out	open-drain with internal pullup 20..50k IN (Power-On) L: Testmode OUT L: data in sendbuffer	44	N.C.	not connected
21	PDI		internal use, do not connect	45	N.C.	not connected
22	PDO		internal use, do not connect	46	N.C.	not connected
23	N.C.		do not connect, reserved	47	N.C.	not connected
24	N.C.		do not connect, reserved	48	N.C.	not connected

### BAUD RATES

The baud rate is set by means of pins 6, 7 and 8 (baud 0 to 2). The data format is set permanently to 8 data bits, 1 stop bit, no parity. RTS/CTS handshake lines are not required. The required control is taken over by the integrated software protocol (see pages 8 and 9).

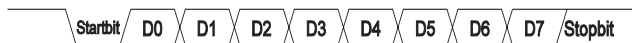

Baud Rates			
Baud0	Baud1	Baud2	data format 8,N,1
0	0	0	1200
1	0	0	2400
0	1	0	4800
1	1	0	9600
0	0	1	19200
1	0	1	38400
0	1	1	57600
1	1	1	115200

### RS-485 INTERFACE

With an external converter (e.g. SN75176), the EA eDIP320 can be connected to a 2-wire RS-485 bus. Large distances of up to 1200 m can thus be implemented (remote display). Several EA eDIP320 displays can be operated on a single RS-485 bus by setting addresses.

We recommend the EA 9778-1RS485 board for development.

Addressing:

- Up to eight hardware addresses (0 to 7) can be set by means of pins ADR0 to ADR2.
- The eDIP with the address 7 is selected and ready to receive after power-on.
- The eDIPs with the addresses 0 to 6 are deselected after power-on.
- Up to 246 further software addresses can be set by means of the '#KA adr' command in the power-on macro (set the eDIP externally to the address 0).

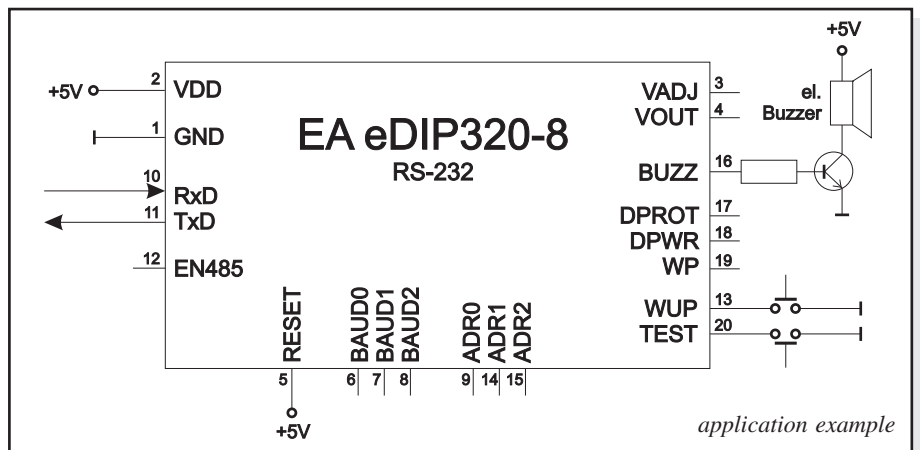

## SPI INTERFACE

If the display is wired as shown below, SP mode is activated. The data is then transferred via the serial, synchronous SPI interface.

Data transfer is possible at up to 100 kHz. However, if pauses of at least 100  $\mu$ s are maintained between the individual bytes during transfer, a byte can be transferred at up to 3 MHz.

**Note:**

The pins DORD, CPOL, CPHA, WUP, DPROT and TEST/SBUF have an internal pullup, which is why only the LO level (0=GND) is to be actively applied. These pins must be left open for a Hi level.

On pin 20 (SBUF) the display indicates with a low level that data is ready to be retrieved from the internal send buffer. The line can be connected to an interrupt input of the host system, for example.

Pinout eDIP320-8: SPI mode						
Pin	Symbol	In/Out	Function	Pin	Symbol	Function
1	GND	-	Ground Potential for logic (0V)	25	N.C.	not connected
2	VDD	-	Power supply for logic (+5V)	26	N.C.	not connected
3	VADJ	In	Operating voltage for LC driving (input)	27	N.C.	not connected
4	VOUT	Out	Output voltage for LC driving	28	N.C.	not connected
5	RESET	-	L: Reset	29	N.C.	not connected
6	SS	In	Slave Select	30	N.C.	not connected
7	MOSI	In	Serial In	31	N.C.	not connected
8	MISO	Out	Serial Out	32	N.C.	not connected
9	CLK	In	Shift Clock	33	N.C.	not connected
10	DORD	In	Data Order (0=MSB first; 1=LSB first)	34	N.C.	not connected
11	SPIMODE	In	connect to GND for SPI interface	35	N.C.	not connected
12	OUT2	Out	open-drain with internal pullup 20..50k	36	N.C.	not connected
13	WUP	In	L: (Power-On) disable Power-On-Macro L: Wakeup from Powerdownmode	37	N.C.	not connected
14	CPOL	In	Clock Polarity (0=LO 1=HI when idle)	38	N.C.	not connected
15	CPHA	In	Clock Phase (sampled on 0=1st 1=2nd edge)	39	N.C.	not connected
16	BUZZ	Out	Buzzer output	40	N.C.	not connected
17	DPROT	In	L: Disable Smallprotokoll do not connect for normal operation	41	N.C.	not connected
18	DPWR	Out	L: Normal Operation H: Powerdownmode	42	N.C.	not connected
19	WP	In	L: Writeprotect for DataFlash	43	N.C.	not connected
20	TEST SBUF	IN Out	open-drain with internal pullup 20..50k IN (Power-On) L: Testmode OUT L: data in sendbuffer	44	N.C.	not connected
21	PDI		internal use, do not connect	45	N.C.	not connected
22	PDO		internal use, do not connect	46	N.C.	not connected
23	N.C.		do not connect, reserved	47	N.C.	not connected
24	N.C.		do not connect, reserved	48	N.C.	not connected

## DATA TRANSFER SPI

Via the pins DORD, CPOL and CPHA transfer parameter will be set.

Write operation: a clock rate up to 100 kHz is allowed without any stop. Together with a pause of 100  $\mu$ s between every data byte a clock rate up to 3 MHz can be reached.

Read operation: to read data (e.g. the "ACK" byte) a dummy byte (e.g. 0xFF) need to be sent. Note that the EA eDIP320-8 for internal operation does need a short time before providing the data; therefore a short pause of min. 6 $\mu$ s (no activity of CLK line) is needed for each byte. Same is with 100kHz operation.

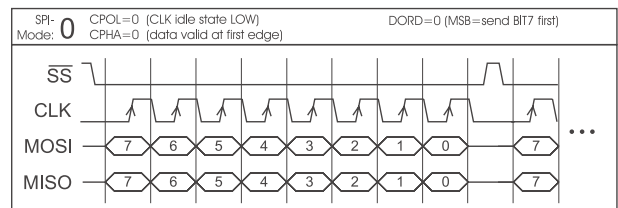
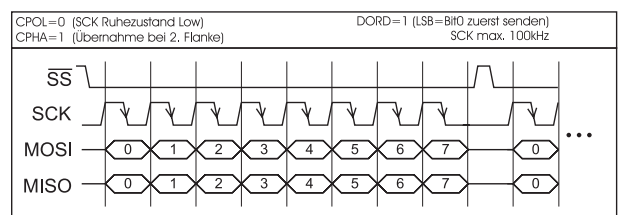
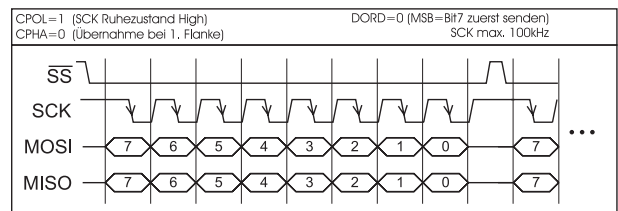
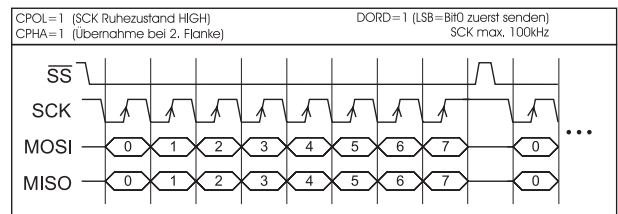
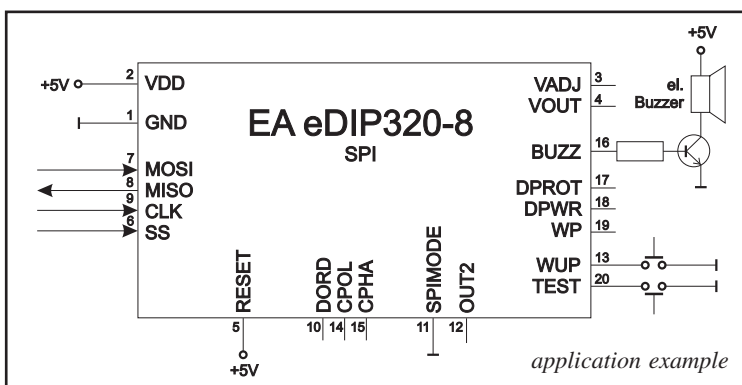

## I<sup>2</sup>C-BUS INTERFACE

If the display is wired as shown below, it can be operated directly on an I<sup>2</sup>C bus. 8 different base addresses and 8 slave addresses can be selected on the display.

Data transfer is possible at up to 100 kHz. However, if pauses of at least 100 μs are maintained between the individual bytes during transfer, a byte can be transferred at up to 400 kHz.

**Note:**

On pin 20 (SBUF) the display indicates with a low level that data is ready to be retrieved from the internal send buffer. The line can be connected to an interrupt input of the host system, for example.

**Note:**

The pins BA0 to 2, SA0 to 2, DPOM, DPROT and TEST/SBUF have an internal pullup, which is why only the LO level (L=0=GND) is to be actively applied. These pins must be left open for a Hi level (H=1).

On pin 20 (SBUF) the display indicates with a low level that data is ready to be retrieved from the internal send buffer.

The line can be connected to an interrupt input of the host system, for example.

Pinout eDIP320-8: I2C mode			
Pin	Symbol	In/Out	Function
1	GND	-	Ground Potential for logic (0V)
2	VDD	-	Power supply for logic (+5V)
3	VADJ	In	Operating voltage for LC driving (input)
4	VOUT	Out	Output voltage for LC driving
5	RESET	-	L: Reset
6	BA0	In	Basic Address 0
7	BA1	In	Basic Address 1
8	SA0	In	Slave Address 0
9	SA1	In	Slave Address 1
10	SA2	In	Slave Address 2
11	BA2	In	Basic Address 2
12	I2CMODE	In	connect to GND for I <sup>2</sup> C interface
13	WUP	In	L: (Power-On) disable Power-On-Macro L: Wakeup from Powerdownmode
14	SDA	Bidir.	Serial Data Line
15	SCL	In	Serial Clock Line
16	BUZZ	Out	Buzzer output
17	DPROT	In	L: Disable Smallprotokoll do not connect for normal operation
18	DPWR	Out	L: Normal Operation H: Powerdownmode
19	WP	In	L: Writeprotect for DataFlash
20	TEST SBUF	IN Out	open-drain with internal pullup 20..50k IN (Power-On) L: Testmode OUT L: data in sendbuffer
21	PDI		internal use, do not connect
22	PDO		internal use, do not connect
23	N.C.		do not connect, reserved
24	N.C.		do not connect, reserved
25	N.C.		not connected
26	N.C.		not connected
27	N.C.		not connected
28	N.C.		not connected
29	N.C.		not connected
30	N.C.		not connected
31	N.C.		not connected
32	N.C.		not connected
33	N.C.		not connected
34	N.C.		not connected
35	N.C.		not connected
36	N.C.		not connected
37	N.C.		not connected
38	N.C.		not connected
39	N.C.		not connected
40	N.C.		not connected
41	N.C.		not connected
42	N.C.		not connected
43	N.C.		not connected
44	N.C.		not connected
45	N.C.		not connected
46	N.C.		not connected
47	N.C.		not connected
48	N.C.		not connected

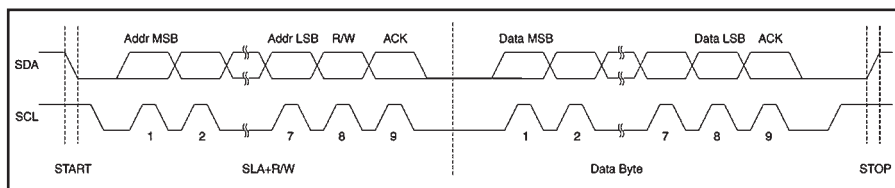

I <sup>2</sup> C - Address											
Pin 11,7,6			Base address	I <sup>2</sup> C address							
BA2	BA1	BA0	address	D7	D6	D5	D4	D3	D2	D1	D0
L	L	L	\$10	0	0	0	1	S A 2	S A 1	S A 0	R W
L	L	H	\$20	0	0	1	0				
L	H	L	\$30	0	0	1	1				
L	H	H	\$40	0	1	0	0				
H	L	L	\$70	0	1	1	1				
H	L	H	\$90	1	0	0	1				
H	H	L	\$B0	1	0	1	1				
H	H	H	\$D0	1	1	0	1				

## DATA TRANSFER I<sup>2</sup>C-BUS

principle I2C-bus transfer:

- I<sup>2</sup>C-Start
- Master-Transmit: EA eDIP-I<sup>2</sup>C-address (e.g. \$DE), send smallprotocol package (data)
- I<sup>2</sup>C-Stop
- I<sup>2</sup>C-Start
- Master-Read: EA eDIP-I<sup>2</sup>C-Address (e.g. \$DF), read ACK-byte and opt. smallprotocoll package (data)
- I<sup>2</sup>C-Stop

all pins open: Write \$DE  
Read \$DF

**Read operation:** for internal operation the EA eDIP does need a short time before providing the data; therefore a short pause of min. 6μs is needed for each byte (no activity of SCL line).

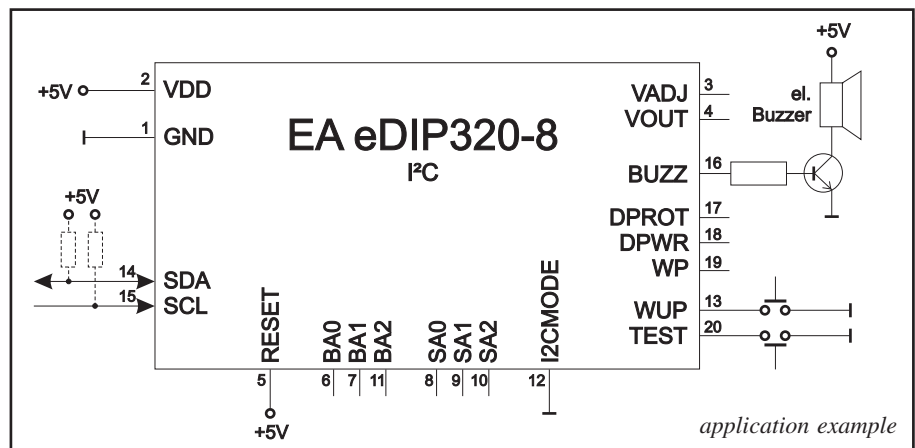

## DATA TRANSFER PROTOCOL (SMALL PROTOCOL)

The protocol has an identical structure for all 3 interface types: RS-232, SPI and I<sup>2</sup>C. Each data transfer is embedded in a fixed frame with a checksum (protocol package). The EA eDIP320-8 acknowledges this package with the character <ACK> (= \$06) on successful receipt or <NAK> (= \$15) in the event of an incorrect checksum or receive buffer overflow. In the case of <NAK>, the entire package is rejected and must be sent again. Receiving the <ACK> byte means only that the protocol package is ok, there is no syntax check for the command.

**Note:** it is necessary to read the <ACK> byte in any case.

If the host computer does not receive an acknowledgment, at least one byte is lost. In this case, the set timeout has to elapse before the package is sent again.

The raw data volume per package is limited to 128 bytes ( $len \leq 128$ ). Commands longer than 128 bytes (e.g. Load image ESC UL...) must be divided up between a number of packages. All data in the packages are compiled again after being correctly received by the EA eDIP320-8.

## DEACTIVATING THE SMALL PROTOCOL

For tests the protocol can be switched off with an L level at pin 17 = DPROT. In normal operation, however, you are urgently advised to activate the protocol. If you do not, any overflow of the receive buffer will not be detected.

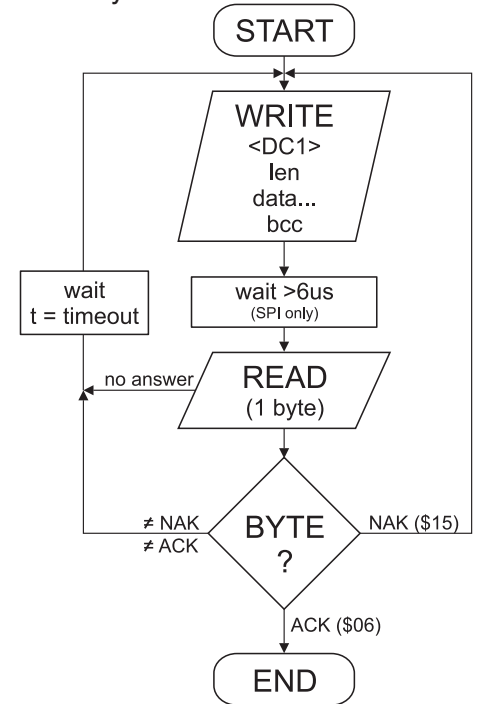

## BUILDING THE SMALLPROTOCOL PACKAGES

### Command/Data to the display

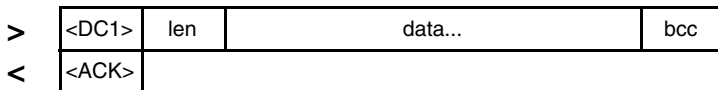

$\langle DC1 \rangle = 17(\text{dec.}) = \$11$       $\langle ACK \rangle = 6(\text{dec.}) = \$06$   
 $len = \text{count of user data (without } \langle DC1 \rangle, \text{ without checksum bcc)}$   
 $bcc = 1 \text{ byte} = \text{sum of all bytes incl. } \langle DC1 \rangle \text{ and len, modulo } 256$

Clear display and draw a line from 0,0 to 319,239

<DC1>	len	ESC	D	L	ESC	G	D	0	0	319	239	bcc	>			
\$11	\$0E	\$1B	\$44	\$4C	\$1B	\$47	\$44	\$00	\$00	\$00	\$00	\$3F	\$01	\$EF	\$00	\$9F

< <ACK>

\$06

*Example to a complete data package*

The user data is transferred framed by <DC1>, the number of bytes (len) and the checksum (bcc). The display responds with <ACK>.

```

void SendData(unsigned char *buf, unsigned char len)
{
    unsigned char i, bcc;

    SendByte(0x11);           // Send DC1
    bcc = 0x11;

    SendByte(len);           // Send data length
    bcc = bcc + len;

    for(i=0; i < len; i++)   // Send buf
    {
        SendByte(buf[i]);
        bcc = bcc + buf[i];
    }

    SendByte(bcc);           // Send checksum
}
    
```

*„C“ source code to transmit a data package*

### Request for content of send buffer

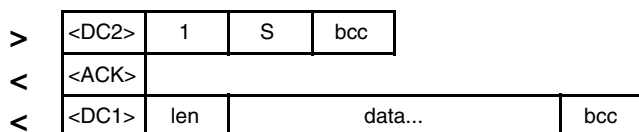

$\langle DC2 \rangle = 18(\text{dec.}) = \$12$       $1 = 1(\text{dez.}) = \$01$       $S = 83(\text{dez.}) = \$53$   
 $\langle ACK \rangle = 6(\text{dec.}) = \$06$   
 $len = \text{count of user data (without } \langle DC2 \rangle, \text{ without checksum bcc)}$   
 $bcc = 1 \text{ byte} = \text{sum of all bytes incl. } \langle DC2 \rangle, \text{ modulo } 256$

The command sequence <DC2>, 1, S, bcc empties the display's send buffer. The display replies with the acknowledgement <ACK> and the begins to send all the collected data such as touch keystrokes.

### Request for buffer information

>	<DC2>	1	I	bcc	
<	<ACK>				
<	<DC2>	2	send buffer bytes ready	receive buffer bytes free	bcc

<DC2> = 18(dec.) = \$12    I = 1(dez.) = \$01    I = 73(dez.) = \$49  
 <ACK> = 6(dec.) = \$06  
 send buffer bytes ready = count of bytes stored in send buffer  
 receive buffer bytes free = count of bytes for free receive buffer  
 bcc = 1 byte = sum of all bytes incl. <DC2>, modulo 256

This command queries whether user data is ready to be picked up and how full the display's receive buffer is.

### Protocol settings

>	<DC2>	3	D	packet size for send buffer	timeout	bcc
<	<ACK>					

<DC2> = 18(dec.) = \$12    3 = 3(dez.) = \$03    D = 68(dez.) = \$44  
 packet size for send buffer = 1..128 (standard: 128)  
 timeout = 1..255 in 1/100 seconds (standard: 200 = 2 seconds)  
 bcc = 1 byte = sum of all bytes incl. <DC2>, modulo 256  
 <ACK> = 6(dec.) = \$06

This is how the maximum package size that can be sent by the display can be limited. The default setting is a package size with up to 128 bytes of user data.

The timeout can be set in increments of 1/100 seconds. The timeout is activated when individual bytes get lost. The entire package then has to be sent again.

### Request for protocol settings

>	<DC2>	1	P	bcc		
<	<ACK>					
<	<DC2>	3	max. packet size	akt. send packet size	akt. timeout	bcc

<DC2> = 18(dec.) = \$12    I = 1(dez.) = \$01    P = 80(dez.) = \$50  
 <ACK> = 6(dec.) = \$06  
 max. packet size = count of maximum user data for 1 package (eDIP320-8 = 128)  
 akt. send packet size = current package size for send  
 akt. timeout = current timeout in 1/100 seconds  
 bcc = 1 byte = sum of all bytes incl. <DC2>, modulo 256

This command is used to query protocol settings.

### Repeat the last package

>	<DC2>	1	R	bcc
<	<ACK>			
<	<DC1>	len	data...	bcc

<DC2> = 18(dec.) = \$12    I = 1(dez.) = \$01    R = 82(dez.) = \$52  
 <ACK> = 6(dec.) = \$06  
 <DC1> = 17(dec.) = \$11  
 len = count of user data in byte (without checksum, without <DC1> or <DC2>)  
 bcc = 1 byte = sum of all bytes incl. <DC2> and len, modulo 256

If the most recently requested package contains an incorrect checksum, the entire package can be requested again. The reply can then be the contents of the send buffer (<DC1>) or the buffer/protocol information (<DC2>).

### Addressing (only for RS232/RS485)

>	<DC2>	3	A	select or deselect	adr	bcc
<	<ACK>					

<DC2> = 18(dec.) = \$12    3 = 3(dez.) = \$03    A = 65(dez.) = \$41  
 select or deselect: 'S' = \$53 or 'D' = \$44  
 adr = 0..255  
 bcc = 1 byte = sum of all bytes incl. <DC2> and adr, modulo 256  
 <ACK> = 6(dec.) = \$06

This command can be used to select or deselect the eDIP with the address adr.

## TOUCH PANEL (EA EDIP320X-8LWTP VERSIONS)

The -xxxTP versions are shipped with an analog, resistive touch panel. Up to 80 touch areas (keys, switches, menus, bar graph inputs) can be defined simultaneously. The fields can be defined with pixel accuracy. The display supports user-friendly commands (see page 16). When the touch “keys” are touched, they can be automatically inverted and an external tone can sound (pin 16), indicating they have been touched. The predefined return code of the “key” is transmitted via the interface, or an internal touch macro with the number of the return code is started instead (see page 19, *Macro programming*).

## TOUCH PANEL ADJUSTMENT

The touch panel is perfectly adjusted and immediately ready for operation on delivery. As a result of aging and wear, it may become necessary to readjust the touch panel.

Adjustment procedure:

1. Touch the touch panel at power-on and keep it depressed. After the message “*touch adjustment ?*” appears, release the touch panel again (or issue the ‘ESC @’ command).
2. Touch the touch panel again within a second for at least a second.
3. Follow the instructions for adjustment (press the 2 points *upper left and lower right*).

## FRAMES AND KEY FORMS

A frame type can be set by using the *Draw frame* or *Draw frame box* command or by drawing touch keys. 18 frame types are available (0 = do not draw a frame). The frame size must be at least 16x16 pixels.

## BITMAPS AS KEYS

Apart from the frame types, which are infinitely scalable, it is also possible to use bitmaps (2 each for *not printed* and *printed*) as touch keys or touch switches.

You can use ELECTRONIC ASSEMBLY LCD-Tools<sup>\*)</sup> to integrate your own buttons as images (“PICTURE” compiler statement). A button always consists of two monochrome Windows BMPs of equal size (one bitmap to display the touch key in its normal state and one for when it is pressed). The active area of the touch key automatically results from the size of the button bitmaps.

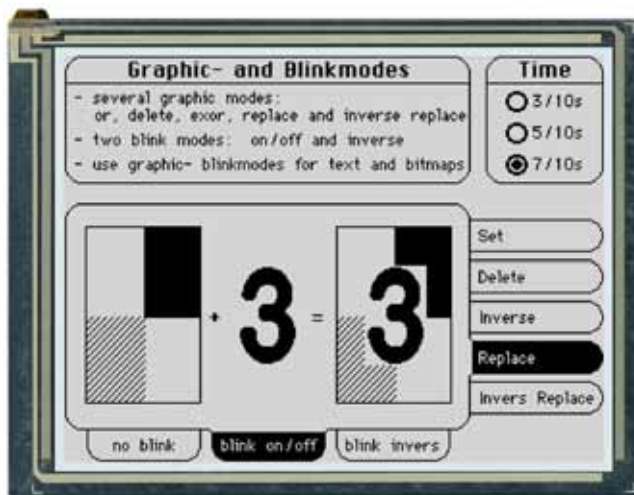

## SWITCHES IN GROUPS (RADIO GROUPS)

Touch switches (radio buttons) change their status from *ON* to *OFF* or vice versa each time they are touched. Several touch switches can be included in a group (‘ESC A R nr’ command). If a touch switch in the group ‘nr’ is switched on, all the other touch switches in this group are automatically switched off. Only one switch is ever on.

<sup>\*)</sup> full version is free available on web at <http://www.lcd-module.com/products/touch.html>

### FILL PATTERN

A pattern type can be set as a parameter with various commands. In this way, for example, rectangular areas and bar graphs can be filled with different patterns. There are 16 internal fill patterns available.

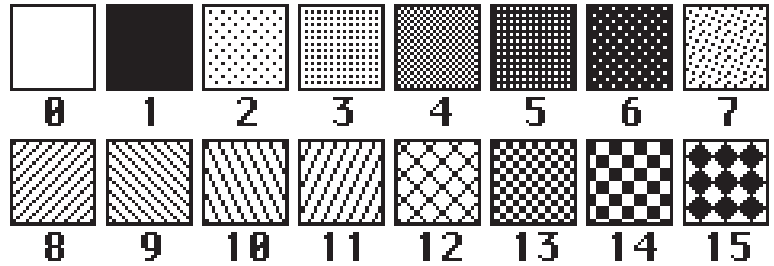

### TERMINAL MODE

When you switch the unit on, the cursor flashes in the first line, indicating that the display is ready for operation. All the incoming characters are displayed in ASCII format on the terminal (exception: CR,LF,FF,ESC,'#'). The prerequisite for this is a working protocol frame (pages 8 and 9) or a deactivated protocol.

Line breaks are automatic or can be executed by means of the 'LF' character. If the last line is full, the contents of the terminal scroll upward. The 'FF' character (page feed) deletes the terminal. The character '#' is used as an escape character and thus cannot be displayed directly on the terminal. If the character '#' is to be output on the terminal, it must be transmitted twice: '##'.

The terminal has its own level for displaying and is thus entirely independent of the graphic outputs. If the graphics screen is deleted with 'ESC DL', for example, that does not affect the contents of the terminal window.

The terminal font is fixed in the ROM and can also be used for graphic outputs 'ESC Z...' (set FONT nr=0).

+ Lower Upper	\$0 (0)	\$1 (1)	\$2 (2)	\$3 (3)	\$4 (4)	\$5 (5)	\$6 (6)	\$7 (7)	\$8 (8)	\$9 (9)	\$A (10)	\$B (11)	\$C (12)	\$D (13)	\$E (14)	\$F (15)
\$20 (dez: 32)		!	"	#	\$	%	&	'	(	)	*	+	,	-	.	/
\$30 (dez: 48)	0	1	2	3	4	5	6	7	8	9	:	;	<	=	>	?
\$40 (dez: 64)	a	b	c	d	e	f	g	h	i	j	k	l	m	n	o	
\$50 (dez: 80)	p	q	r	s	t	u	v	w	x	y	z	[	\	]	^	_
\$60 (dez: 96)	~	a	b	c	d	e	f	g	h	i	j	k	l	m	n	o
\$70 (dez: 112)	p	q	r	s	t	u	v	w	x	y	z	{		}	~	Δ
\$80 (dez: 128)	€	ü	é	û	ä	à	ç	ê	ë	è	ï	î	ì	ñ	Á	
\$90 (dez: 144)	é	æ	œ	ö	ö	ö	ü	ü	ü	ö	ü	ç	£	¥	β	f
\$A0 (dez: 160)	á	í	ó	ú	ñ	ñ	ë	ó	ç	í	í	½	¼	i	«	»
\$B0 (dez: 176)																
\$C0 (dez: 192)																
\$D0 (dez: 208)																
\$E0 (dez: 224)	α	β	Γ	π	Σ	σ	μ	τ	ϕ	θ	η	δ	φ	ε	π	
\$F0 (dez: 240)	≡	±	≥	≤	ρ	∫	÷	≈	°	*	.	√	∞	z	z	-

Terminal-Font (Font 0): 8x8 monospaced

EA eDIP320-8: Terminal commands							After reset	
Command	Codes		Remarks					
Form feed ff (dec:12)	^L		The contents of the screen are deleted and the cursor is placed at pos. (1,1)					
carriage return CR(13)	^M		Cursor to the beginning of the line on the extreme left					
line feed lf (dec:10)	^J		Cursor 1 line lower, if cursor in last line then scroll					
Position cursor	ESC	T	P	C	L		C=column; L=line; origin upper-left corner (1,1)	1,1
Cursor on/off			C	n1			n1=0: Cursor is invisible; n1=1: Cursor flashes;	1
save cursor position			S				the current cursor position is saved	
restore cursor position			R				the last saved cursor position is restored	
Terminal off			A				Terminal display is switched off; outputs are rejected	
Terminal on			E				Terminal display is switched on;	On
output version			V				the version no. is output in the terminal (e.g. "EA eDIP320-8 V1.0 Rev.A")	
Define window	ESC	T	W	C	L	B H w	The terminal output is executed only within the window from column C and line Z (=upper-left corner) with a width of b and a height of h (specifications in characters); w=angle (0=0°; 1=90°; 2=180°; 3=270°) of the terminal display	1,1 40,30 0

## INTEGRATED AND EXTERNAL FONTS

As standard, there are 3 monospaced character sets, 3 proportional character sets and 1 large digit font integrated in addition to the 8x8 terminal font (font no. 0). The proportional character sets (which have a narrow "l" and a wide "W", for example) look better and take up less space on the screen. Each character can be placed with **pixel accuracy**, and its height and width can be increased by a factor of 1 to 8.

A text can be output left justified, right justified or centered. Rotation in 90° steps is possible (for vertical installation of the display, for example).

Macro programming permits further fonts to be integrated (up to 31). All kinds of fonts can be created using a text editor and loaded using the eDIP320 compiler\* (the USB programmer EA 9778-1USB is required).

+ Lower Upper	\$0 (0)	\$1 (1)	\$2 (2)	\$3 (3)	\$4 (4)	\$5 (5)	\$6 (6)	\$7 (7)	\$8 (8)	\$9 (9)	\$A (10)	\$B (11)	\$C (12)	\$D (13)	\$E (14)	\$F (15)
\$20 (dez: 32)		!	"	#	\$	%	&	'	(	)	*	+	,	-	.	/
\$30 (dez: 48)	0	1	2	3	4	5	6	7	8	9	:	;	<	=	>	?
\$40 (dez: 64)	@	A	B	C	D	E	F	G	H	I	J	K	L	M	N	O
\$50 (dez: 80)	P	Q	R	S	T	U	V	W	X	Y	Z	[	\	]	^	_
\$60 (dez: 96)	`	a	b	c	d	e	f	g	h	i	j	k	l	m	n	o
\$70 (dez: 112)	p	q	r	s	t	u	v	w	x	y	z	{		}	~	Δ
\$80 (dez: 128)	€	ü	é	â	ä	à	ç	ê	ë	è	ï	î	í	ñ	ñ	
\$90 (dez: 144)	É	æ	Æ	ô	ö	ò	û	ù	ÿ	ÿ	ÿ	ÿ	ÿ	ÿ	ÿ	ÿ
\$A0 (dez: 160)	á	í	ó	ú	ñ	ñ	á	ó	¿	¡	½	¼	i	«	»	
\$B0 (dez: 176)																
\$C0 (dez: 192)																
\$D0 (dez: 208)																
\$E0 (dez: 224)	α	β	Γ	π	Σ	φ	μ	ν	ξ	θ	Ω	δ	ϕ	ϕ	ε	Π
\$F0 (dez: 240)	≡	±	≥	≤	Γ	J	÷	≈	•	•	•	•	•	•	•	•

Font 1: 4x6 monospaced

+ Lower Upper	\$0 (0)	\$1 (1)	\$2 (2)	\$3 (3)	\$4 (4)	\$5 (5)	\$6 (6)	\$7 (7)	\$8 (8)	\$9 (9)	\$A (10)	\$B (11)	\$C (12)	\$D (13)	\$E (14)	\$F (15)
\$20 (dez: 32)		!	"	#	\$	%	&	'	(	)	*	+	,	-	.	/
\$30 (dez: 48)	0	1	2	3	4	5	6	7	8	9	:	;	<	=	>	?
\$40 (dez: 64)	@	A	B	C	D	E	F	G	H	I	J	K	L	M	N	O
\$50 (dez: 80)	P	Q	R	S	T	U	V	W	X	Y	Z	[	\	]	^	_
\$60 (dez: 96)	`	a	b	c	d	e	f	g	h	i	j	k	l	m	n	o
\$70 (dez: 112)	p	q	r	s	t	u	v	w	x	y	z	{		}	~	Δ
\$80 (dez: 128)	€	ü	é	â	ä	à	ç	ê	ë	è	ï	î	í	ñ	ñ	
\$90 (dez: 144)	É	æ	Æ	ô	ö	ò	û	ù	ÿ	ÿ	ÿ	ÿ	ÿ	ÿ	ÿ	ÿ
\$A0 (dez: 160)	á	í	ó	ú	ñ	ñ	á	ó	¿	¡	½	¼	i	«	»	
\$B0 (dez: 176)																
\$C0 (dez: 192)																
\$D0 (dez: 208)																
\$E0 (dez: 224)	α	β	Γ	π	Σ	φ	μ	ν	ξ	θ	Ω	δ	ϕ	ϕ	ε	Π
\$F0 (dez: 240)	≡	±	≥	≤	Γ	J	÷	≈	•	•	•	•	•	•	•	•

Font 3: 7x12 monospaced

+ Lower Upper	\$0 (0)	\$1 (1)	\$2 (2)	\$3 (3)	\$4 (4)	\$5 (5)	\$6 (6)	\$7 (7)	\$8 (8)	\$9 (9)	\$A (10)	\$B (11)	\$C (12)	\$D (13)	\$E (14)	\$F (15)
\$20 (dez: 32)		!	"	#	\$	%	&	'	(	)	*	+	,	-	.	/
\$30 (dez: 48)	0	1	2	3	4	5	6	7	8	9	:	;	<	=	>	?
\$40 (dez: 64)	@	A	B	C	D	E	F	G	H	I	J	K	L	M	N	O
\$50 (dez: 80)	P	Q	R	S	T	U	V	W	X	Y	Z	[	\	]	^	_
\$60 (dez: 96)	`	a	b	c	d	e	f	g	h	i	j	k	l	m	n	o
\$70 (dez: 112)	p	q	r	s	t	u	v	w	x	y	z	{		}	~	Δ
\$80 (dez: 128)	€	ü	é	â	ä	à	ç	ê	ë	è	ï	î	í	ñ	ñ	
\$90 (dez: 144)	É	æ	Æ	ô	ö	ò	û	ù	ÿ	ÿ	ÿ	ÿ	ÿ	ÿ	ÿ	ÿ
\$A0 (dez: 160)	á	í	ó	ú	ñ	ñ	á	ó	¿	¡	½	¼	i	«	»	
\$B0 (dez: 176)																
\$C0 (dez: 192)																
\$D0 (dez: 208)																
\$E0 (dez: 224)	α	β	Γ	π	Σ	φ	μ	ν	ξ	θ	Ω	δ	ϕ	ϕ	ε	Π
\$F0 (dez: 240)	≡	±	≥	≤	Γ	J	÷	≈	•	•	•	•	•	•	•	•

Font 2: 6x8 monospaced

+ Lower Upper	\$0 (0)	\$1 (1)	\$2 (2)	\$3 (3)	\$4 (4)	\$5 (5)	\$6 (6)	\$7 (7)	\$8 (8)	\$9 (9)	\$A (10)	\$B (11)	\$C (12)	\$D (13)	\$E (14)	\$F (15)
\$20 (dez: 32)		!	"	#	\$	%	&	'	(	)	*	+	,	-	.	/
\$30 (dez: 48)	0	1	2	3	4	5	6	7	8	9	:	;	<	=	>	?
\$40 (dez: 64)	@	A	B	C	D	E	F	G	H	I	J	K	L	M	N	O
\$50 (dez: 80)	P	Q	R	S	T	U	V	W	X	Y	Z	[	\	]	^	_
\$60 (dez: 96)	`	a	b	c	d	e	f	g	h	i	j	k	l	m	n	o
\$70 (dez: 112)	p	q	r	s	t	u	v	w	x	y	z	{		}	~	Δ
\$80 (dez: 128)	€	ü	é	â	ä	à	ç	ê	ë	è	ï	î	í	ñ	ñ	
\$90 (dez: 144)	É	æ	Æ	ô	ö	ò	û	ù	ÿ	ÿ	ÿ	ÿ	ÿ	ÿ	ÿ	ÿ
\$A0 (dez: 160)	á	í	ó	ú	ñ	ñ	á	ó	¿	¡	½	¼	i	«	»	
\$B0 (dez: 176)																
\$C0 (dez: 192)																
\$D0 (dez: 208)																
\$E0 (dez: 224)	α	β	Γ	π	Σ	φ	μ	ν	ξ	θ	Ω	δ	ϕ	ϕ	ε	Π
\$F0 (dez: 240)	≡	±	≥	≤	Γ	J	÷	≈	•	•	•	•	•	•	•	•

Font 4: GENEVA10 proportional

+ Lower Upper	\$0 (0)	\$1 (1)	\$2 (2)	\$3 (3)	\$4 (4)	\$5 (5)	\$6 (6)	\$7 (7)	\$8 (8)	\$9 (9)	\$A (10)	\$B (11)	\$C (12)	\$D (13)	\$E (14)	\$F (15)
\$20 (dez: 32)		!	"	#	\$	%	&	'	(	)	*	+	,	-	.	/
\$30 (dez: 48)	0	1	2	3	4	5	6	7	8	9	:	;	<	=	>	?
\$40 (dez: 64)	@	A	B	C	D	E	F	G	H	I	J	K	L	M	N	O
\$50 (dez: 80)	P	Q	R	S	T	U	V	W	X	Y	Z	[	\	]	^	_
\$60 (dez: 96)	`	a	b	c	d	e	f	g	h	i	j	k	l	m	n	o
\$70 (dez: 112)	p	q	r	s	t	u	v	w	x	y	z	{		}	~	Δ
\$80 (dez: 128)	€	ü	é	â	ä	à	ç	ê	ë	è	ï	î	í	ñ	Å	
\$90 (dez: 144)	É	æ	Æ	ô	ö	ò	û	ù	ÿ	ÿ	ÿ	ÿ	ÿ	ÿ	ÿ	ÿ
\$A0 (dez: 160)	á	í	ó	ú	ñ	Ñ	á	o								
\$B0 (dez: 176)																
\$C0 (dez: 192)																
\$D0 (dez: 208)																
\$E0 (dez: 224)		ß														
\$F0 (dez: 240)								°								

Font 5: CHICAGO14 proportional

+ Lower Upper	\$0 (0)	\$1 (1)	\$2 (2)	\$3 (3)	\$4 (4)	\$5 (5)	\$6 (6)	\$7 (7)	\$8 (8)	\$9 (9)	\$A (10)	\$B (11)	\$C (12)	\$D (13)	\$E (14)	\$F (15)
\$20 (dez: 32)		!	"	#	\$	%	&	'	(	)	*	+	,	-	.	/
\$30 (dez: 48)	0	1	2	3	4	5	6	7	8	9	:	;	<	=	>	?
\$40 (dez: 64)	@	A	B	C	D	E	F	G	H	I	J	K	L	M	N	O
\$50 (dez: 80)	P	Q	R	S	T	U	V	W	X	Y	Z	[	\	]	^	_
\$60 (dez: 96)	`	a	b	c	d	e	f	g	h	i	j	k	l	m	n	o
\$70 (dez: 112)	p	q	r	s	t	u	v	w	x	y	z	{		}	~	Δ
\$80 (dez: 128)	€	ü	é	â	ä	à	ç	ê	ë	è	ï	î	í	ñ	Å	
\$90 (dez: 144)	É	æ	Æ	ô	ö	ò	û	ù	ÿ	ÿ	ÿ	ÿ	ÿ	ÿ	ÿ	ÿ
\$A0 (dez: 160)	á	í	ó	ú	ñ	Ñ	á	o								
\$B0 (dez: 176)																
\$C0 (dez: 192)																
\$D0 (dez: 208)																
\$E0 (dez: 224)		ß														
\$F0 (dez: 240)								°								

Font 6: Swiss30 Bold proportional

+ Lower Upper	\$0 (0)	\$1 (1)	\$2 (2)	\$3 (3)	\$4 (4)	\$5 (5)	\$6 (6)	\$7 (7)	\$8 (8)	\$9 (9)	\$A (10)	\$B (11)	\$C (12)	\$D (13)	\$E (14)	\$F (15)
\$20 (dez: 32)												+	-	.		
\$30 (dez: 48)	0	1	2	3	4	5	6	7	8	9	:					

Font 7: large Digits BigZif57

**FONT APPEARANCE**

This hard copy shows all the fonts with which the product is shipped.

Macro programming permits them to be modified or further fonts to be integrated. All kinds of fonts (including Cyrillic and Chinese) can be created using a text editor and programmed using the kit compiler/LCD toolkit<sup>\*)</sup> (the EA 9778-1USB programmer is required).



<sup>\*)</sup> full version is free available on web at <http://www.lcd-module.com/products/touch.html>

## ALL COMMANDS AT A GLANCE

The built-in intelligence allows an easy creation of your individual screen content. Below mentioned commands can be used either directly via the serial interface (see page 17) or together with the self-definable macro (see pages 19/20).

EA eDIP320-8: Command table 1										After reset				
Command	Codes				Remarks									
<b>Commands for outputting strings</b>														
Output string L: left justified C: centered R: right justified	ESC	Z	L	xx1	yy1	text ...	NUL	A string (...) is output to xx1,yy1; end of string: 'NUL' (\$00), 'LF' (\$0A) or 'CR' (\$0D); several lines are separated by the character ' ' (\$7C); text between two '^' (\$7E) characters flashes on/off; text between two '@' (\$40) characters flashes inversely;						
Set font			F	n1				Set font with the number n1 (0 to 31)			0			
Font zoom factor			Z	n1	n2				n1 = X zoom factor (1x to 8x); n2 = Y zoom factor (1x to 8x)			1,1		
Add. line spacing			Y	n1				insert n1 pixels (0 to 15) between two lines as additional line spacing						
Text angle			W	n1				Text output angle: n1=0: 0°; n1=1: 90°; n1=2: 180°; n1=3: 270°			0			
Text link mode			V	n1				Mode n1: 1=set; 2=delete; 3=inverse; 4=replace; 5=inverse replace;			4			
Text pattern			M	n1				link Text with pattern number n1 (0 to 15);			1			
Text flashing attribute			B	n1				n1: 0=no flashing; 1=Text flashes on/off; 2=Text flashes inversely			0			
String for terminal			ESC	Z	T	text ...			Command for outputting a string from a macro to the terminal					
<b>Draw straight lines and points</b>														
Draw rectangle	ESC	G	R	xx1	yy1	xx2	yy2	Draw four straight lines as a rectangle from xx1,yy1 to xx2,yy2						
Draw straight line			D	xx1	yy1	xx2	yy2	Draw straight line from xx1,yy1 to xx2,yy2						
Continue straight line			W	xx1	yy1				Draw a straight line from last end point to xx1, yy1			0		
Draw point			P	xx1	yy1				Set a point at coordinates xx1, yy1					
Point size/line thickness			Z	n1	n2				n1 = X point size (1 to 15); n2 = Y point size (1 to 15);			1,1		
Link mode			V	n1				Set drawing mode n1: 1=set; 2=delete; 3=inverse;			1			
Pattern			M	n1				set straight line/point pattern number n1 (0 to 15)			1			
<b>Change/draw rectangular areas</b>														
Delete area	ESC	R	L	xx1	yy1	xx2	yy2	Delete area from xx1,yy1 to xx2,yy2 (all pixels off)						
Invert area			I	xx1	yy1	xx2	yy2	Invert area from xx1,yy1 to xx2,yy2 (invert all pixels)						
Fill area			S	xx1	yy1	xx2	yy2	Fill area from xx1,yy1 to xx2,yy2 (all pixels on)						
Area with fill pattern			M	xx1	yy1	xx2	yy2	n1	Draw area from xx1,yy1 to xx2,yy2 with pattern n1 (always set)					
Draw box			O	xx1	yy1	xx2	yy2	n1	Draw rectangle from xx1,yy1 to xx2,yy2 with pattern n1 (always replace)					
Draw frame			R	xx1	yy1	xx2	yy2	n1	Draw frame of type n1 from xx1,yy1 to xx2,yy2 (always set)					
Draw frame box			T	xx1	yy1	xx2	yy2	n1	Draw frame box of type n1 from xx1,yy1 to xx2,yy2 (always replace)					
<b>Bitmap image commands</b>														
Image from clipboard	ESC	U	C	xx1	yy1				The current contents of the clipboard are loaded to xx1,yy1 with all the image attributes					
Load internal image			I	xx1	yy1	no				Load internal image with the no (0 to 255) from the data flash memory to xx1,yy1				
Load image			L	xx1	yy1	Bh7 data ...			Load an image to xx1,yy1; see image structure (BH7 format) for image data					
Image zoom factor			O	n1	n2				n1 = X zoom factor (1x to 8x); n2 = Y zoom factor (1x to 8x)		1,1			
Image angle			W	n1				output angle of the image: n1=0: 0°; n1=1: 90°; n1=2: 180°; n1=3: 270°		0				
Mirror Image			X	n1				n1: 0=normal display; 1=the image is mirrored horizontally		0				
Image link mode			V	n1				Mode n1: 1=set; 2=delete; 3=inverse; 4=replace; 5=inverse replace;		4				
Image pattern			M	n1				link Text with pattern number n1 (0 to 15)		1				
Image flashing attribute			B	n1				n1: 0=no flashing; 1=image flashes on/off; 2=image flashes inversely; 3=flashes with flash image		0				
Send hard copy			H	xx1	yy1	xx2	yy2				After this command, the image extract is sent in BH7 Format.			
<b>Display commands (effect on the entire display)</b>														
Delete display	ESC	D	L				Delete display contents (all pixels off)							
Invert display			I				Invert display contents (invert all pixels)							
Fill display			S				Fill display contents (all pixels on)							
Switch display off			A				Display contents become invisible but are retained, commands are still possible							
Switch display on			E				Display contents become visible again			On				
<b>Flashing area commands</b>														
Delete flashing attribute	ESC	Q	L	xx1	yy1	xx2	yy2	Delete the flashing attribute from xx1,yy1 to xx2,yy2						
Flash inversely			I	xx1	yy1	xx2	yy2	Defines an inverted flashing area from xx1,yy1 to xx2,yy2						
Flashing area pattern			M	xx1	yy1	xx2	yy2	n1	Defines a flashing area with pattern n1 (on/off) from xx1,yy1 to xx2,yy2					
Set flashing time			Z	n1				Set the flashing time n1= 1 to 15 in 1/10s; 0=deactivate flashing function			6			
<b>Bar graph commands</b>														
Define bar graph	ESC	B	R	no	xx1	yy1	xx2	yy2	SV	EV	Typ	pat	Define bar graph to L(ef), R(ight), O(ben) (up), U(nten) (down) with number no. xx1,yy1,xx2,yy2 form the rectangle enclosing the bar graph. sv, ev a bar values for 0% and 100%. Type: 0=bar; 1=bar in rectangle; pat=bar pattern; type: 2=line; 3=line in rectangle; pat=line width	
Update bar graph			A	n1	valu				Set and draw the bar graph with the number n1 to the new user 'value'.					
Draw new bar graph			Z	n1				entirely reDraw the bar graph with the number n1						
Send bar graph value			S	n1				Send the current value of bar graph number n1						
Delete bar graph			D	n1	n2				the definition of the bar graph with the number n1 becomes invalid. If the bar graph was defined as input with touch, this touch field will also be deleted. n2=0: Bar graph remains visible; n2=1: Bar graph is deleted					

EA eDIP320-8: Command table 2							After reset			
Command	Codes		Remarks							
<b>Clipboard commands (buffer for image areas)</b>										
Save display contents	ESC	C	B				The entire contents of the display are copied to the clipboard as an image area			
Save area			S	xx1	yy1	xx2	yy2	The image area from xx1,yy1 to xx2,yy2 is copied to the clipboard		
Restore area			R					The image area on the clipboard is copied back to the display		
Copy area			K	xx1	yy1			The image area on the clipboard is copied to xx1,yy1 in the display		
<b>settings for menu box/touch menu</b>										
Set menu font	ESC	N	F	n1			Set font with the number n1 (0 to 31) for menu display	0		
Menu font zoom factor			Z	n1	n2	n1 = X zoom factor (1x to 8x); n2 = Y zoom factor (1x to 8x)		1,1		
Add. line spacing			Y	n1	Insert n1 pixels (0 to 15) between two menu items as additional line spacing					
Menu angle			W	n1	Menu display angle: n1=0: 0°; n1=1: 90°; n1=2: 180°; n1=3: 270°				0	
Touch menu automation			T	n1	n1=1: Touch menu opens automatically; n1=0: Touch menu does not open automatically; instead, the request 'ESC T 0' to open is sent to the host computer, which can then open the touch menu with 'ESC N T 2'.				1	
<b>Menu box commands (control with keys rather than by touch)</b>										
Define and display menu	ESC	N	D	xx1	yy1	no	text ...	NUL	A menu is drawn as of the corner xx1,yy1 with the current menu font. no= currently inverted entry (e.g.: 1 = 1. entry) Text:= string with menu items. The different items are separated by the character '!' (\$7C,dec:124) (e.g. "item1!item2!item3"). The background of the menu is saved automatically. If a menu is already defined, it is automatically canceled+deleted.	
Next item			N	The next item is inverted or remains at the end						
Previous item			P	The previous item is inverted or remains at the beginning						
End of menu/send			S	The menu is removed and replaced with the original background. The current item is sent as a number (1 to n) (0=no menu displayed)						
End of menu/macro			M	n1	The menu is removed and replaced with the original background. Menu macro n1 is called for item 1, menu macro nr+1 for item 2, and so on					
End of menu/cancel			A	The menu is removed and replaced with the original background						
<b>Macro commands</b>										
Run normal macro	ESC	M	N	n1				Call the (normal) macro with the number n1 (0 to 255) (max. 7 levels)		
Run touch macro			T	n1				Call the touch macro with the number n1 (0 to 255) (max. 7 levels)		
Run menu macro			M	n1				Call the menu macro with the number n1 (0 to 255) (max. 7 levels)		
Disable macros			L	type	n1	n2			Macros of the type 'N', 'T' or 'M' (type 'A' = all macro types) are disabled from the number n1 to n2; i.e. no longer run when called.	
Enable macros			U	type	n1	n2			Macros of the type 'N', 'T' or 'M' (type 'A' = all macro types) are enabled from number n1 to n2; i.e. run again when called.	
Select macro/image page			K	n1	A page is selected for macros and images n1=0 to 15. if a macro/image is not defined in the current page 1 to 15, this macro/image is taken from page 0 (e.g. to switch languages or for horizontal/vertical installation).					
Save macro/image page			W	the current macro/image page is saved (when used in process macros)						
Restore macro/image page			R	the last saved macro/image page is restored						
<b>automatic (Normal) Macros</b>										
Macro with delay	ESC	M	G	n1	n2			Call the (normal) macro with the number n1 (0 to 255) in n2/10S. Execution is stopped by commands (e.g. receipt or touch macros).		
Autom. macros once only			E	n1	n2	n3	Automatically run macros n1 to n2 once only; n3=pause in 1/10s. Execution is stopped by commands (e.g. receipt or touch macros).			
Autom. macros cyclical			A	n1	n2	n3	Automatically run macros n1 to n2 cyclically; n3=pause in 1/10s. Execution is stopped by commands (e.g. receipt or touch macros).			
Autom. macros ping pong			J	n1	n2	n3	Automatically run macros n1 to n2 to n1 (ping pong); n3=pause in 1/10s. Execution is stopped, for example, by receipt or touch macros.			
<b>macro processes</b>										
Define macro process	ESC	M	D	no	type	n3	n4	zs	A macro process with the number no (1 to 8) is defined (1=highest priority). The (Normal) Macros n3 to n4 are run successively every zs/10s. type: 1=once only; 2=cyclical; 3=ping pong n3 to n4 to n3	
Macro process interval			Z	nr	zs	a new time zs is assigned to the macro process with the number nr (1 to 8) in 1/10s. if the time zs=0, execution is stopped.				
Stop macro processes			S	n1	all macro processes are stopped with n1=0 and restarted with n1=1 in order, for example, to execute settings and outputs via the interface undisturbed					
<b>Other commands</b>										
Wait (pause)	ESC	X	n1	Wait n1 tenths of a second before the next command is executed.						
Set RS485 address	ESC	K	A	adr	for RS232/RS485 operation only and only possible when Hardware address is 0. The eDIP is assigned a new address adr (in the Power-On macro).					
Tone on/off	ESC	Y	S	n1				The tone output (pin 16) becomes n1=0: OFF; n1=1: ON; n1=2 to 255: switched on for n1 tenths of a second		
Illumination on/off			L	n1	LED illumination n1=0: OFF; n1=1: ON; n1=2 to 255: illumination switched on for n1 tenths of a second.					
Illumination brightness			H	n1	set brightness of the LED illumination n1=0 to 100%. n1=250 save current brightness as starting brightness; n1=254 switch LED off immediately; n1=255 switch to 100% immediately.					
Write output port			W	n1	n2	n1=0: Set all output ports in accordance with n2 (=6/8-bit binary value). n1=1 to 6/8: Reset port n1 (n2=0); set (n2=1); invert (n2=2);				
Send bytes	ESC	S	B	num	data ...			num (=1 to 255) bytes are sent to the send buffer... = num Bytes. in the source text of the macro programming, the number nUM must not be specified. This is counted by the edip compiler and entered.		
Send version			V	the version is sent as a string (e.g. "EA eDIP320-8 V1.0 Rev.A tp+")						
Send internal information			I	internal information is sent by the edip.						
Power down	ESC	P	D	n1	After this command, the display goes into power-down mode. n1=0: wake up only after reset; n1=1: wake up on L level at WUP Pin n1=2: wake up on touch; n1=3: wake up on WUP Pin or Touch					

EA eDIP320-8: Commands for the touch panel											After reset			
Command	Codes		Remarks											
<b>Touch: Define areas</b>														
Define touch key (key remains depressed as long as there is contact)	ESC	A	T	xx1	yy1	xx2	yy2	dow code	up code	text ...	NUL	'T': The area from xx1,yy1 to xx2,yy2 is defined as a key. 'U': Image no. n1 is loaded to xx1,yy2 and defined as a key. 'down code':(1-255) Return/touch macro when key pressed. 'up code': (1-255) Return/touch macro when key released. (down/up code = 0 press/release not reported). 'text': the first character determines the alignment of the text (C=centered, L=left justified, R=right justified). this is followed by a string that is placed in the key with the current touch font. multiline texts are separated with the character ' ' (\$7C, dec: 124); 'nul': (\$00) = end of string		
			U	xx1	yy1	n1	dow code	up code	text ...	NUL				
Define touch switch (status of the switch toggles after each contact)	ESC	A	K	xx1	yy1	xx2	yy2	dow code	up code	text ...	NUL	'K': The area from xx1,yy1 to xx2,yy2 is defined as a switch. 'J': Image no. n1 is loaded to xx1,yy2 and defined as a switch. 'down code': (1-255) Return/touch macro when switched on. 'up code': (1-255) Return/touch macro when switched off. (down/up code = 0 on/off not reported). 'text': the first character determines the alignment of the text (C=centered, L=left justified, R=right justified). this is followed by a string that is placed in the key with the current touch font. multiline texts are separated with the character ' ' (\$7C, dec: 124); 'nul': (\$00) = end of string		
			J	xx1	yy1	n1	dow code	up code	text ...	NUL				
Define touch key with menu function	ESC	A	M	xx1	yy1	xx2	yy2	dow code	up code	mnu code	text ...	NUL	The area from xx1,yy1 to xx2,yy2 is defined as a menu key. 'down code':(1-255) Return/touch macro when pressed. 'up Code':(1-255) Return/touch macro when menu canceled 'mnu Code':(1-255) Return/menu macro+(item no. 1) after selection of a menu item. (down/up code = 0: activation/cancellation is not reported.) 'text':= string with the key text and the menu items. the first character determines the direction in which the menu opens (R=right, L=left, O=up, U=down). The second character determines the alignment of the touch key text (C=centered, L=left justified, R=right justified). The menu items are separated by the character ' ' (\$7C,dec:124) (e.g. "uckey item1 item2 item3". The key text is written with the current touch font and the menu items are written with the current menu font. The background of the menu is saved automatically.	
Define drawing area	ESC	A	D	xx1	yy1	xx2	yy2	n1				A drawing area is defined. You can then draw with a line width of n1 within the corner coordinates xx1,yy1 and xx2,yy2.		
Define free touch area	ESC	A	H	xx1	yy1	xx2	yy2				A freely usable touch area is defined. Touch actions (down, up and drag) within the corner coordinates xx1,yy1 and xx2,yy2 are sent.			
Set bar by touch	ESC	A	B	n1							The bar graph with the no. n1 is defined for input by touch panel.			
<b>Touch: settings</b>														
Touch frame form	ESC	A	E	n1							The frame type for the display of touch keys/switches is set with n1	1		
Touch key response			I	n1							Automatic inversion when touch key touched: n1=0=OFF; n1=1=ON;	1		
Invert touch key			S	n1							Tone sounds briefly when a touch key is touched: n1=0=OFF; n1=1=ON	1		
Query touch switch			N	Cod							The touch key with the assigned return code is inverted manually			
Set touch switch			X	Cod							The status of the switch (off=0; on=1) is placed in the send buffer.			
Radio group for switches			P	Cod	n1							The status of the switch is changed by means of a command (n1=0=off; n1=1=on). Only 1 switch in a group is active at any one time; all the others are deactivated. nr=0: newly defined switches do not belong to a group. nr=1 to 255: newly defined switches belong to the group with the number nr. In the case of a switch in a group, only the down code is applicable. the up code is ignored.	0	
Query radio group			R	n1							the down code of the activated switch from the radio group with the number n1 is placed in the send buffer.			
Delete touch area			G	n1							The touch area with the return code (code=0: all touch areas) is removed from the touch query When n1=0, the area remains visible on the display; when n1=1, the area is deleted.			
Send bar value automatically			L	Cod	n1							remove the Touch area that includes the coordinates xx1,yy1 from the touch query. n1=0: area remains visible; n1=1: Delete area		
Touch query on/off			V	xx1	yy1	n1							The Automatic transmission of a new bar graph value by touch input is deactivated (n1=0); a new value is sent after setting (n1=1); each change is sent during setting (N1=2).	1
Rotate touch query	Q	n1							Touch query is deactivated (n1=0) or activated (n1=1);					
			O	n1							n1=0: normal query; n1=1: Touch query for top view (solder straps changed over)	1		
<b>Touch: Label font</b>														
Label font	ESC	A	F	n1							Set font with the number n1 (0 to 31) for touch key label	0		
Label zoom factor			Z	n1	n2							n1 = X zoom factor (1x to 8x); n2 = Y zoom factor (1x to 8x)	1,1	
Add. line spacing			Y	n1							insert n1 pixels (0 to 15) between two lines of text as additional line spacing			
Label angle			W	n1							Text output angle: n1=0: 0°; n1=1: 90°; n1=2: 180°; n1=3: 270°	0		

Responses of the EA eDIP320-8									
Id	num	data				Remarks			
<b>automatic responses</b>									
ESC	A	1	code				Response from the analog touch panel when a key/switch is pressed. code = down or up code of the key/switch. it is Only transmitted if no touch macro is defined with the no. co		
ESC	N	1	code				After a menu item is selected by touch, the selected menu item code is transmitted. it is Only transmitted if no touch macro is defined with the number code.		
ESC	B	2	no	value				When a bar graph is set by touch, the current value of the bar is transmitted with the nur	
ESC	T	0				Transmission of the bar balue must be activated (see the 'ESC A Q n1' command). if automatic opening of a touch menu is disabled (see the 'ESC N T n1' command), this request is sent to the host computer. The host can then open the touch menu with the 'E T 2' command.			
ESC	H	5	type	xLO	xHI	yLO	yHI	The following is transmitted in the case of a free touch area event: type=0 is release; tp is touch; type=2 is drag within the free touch area at the coordinates XX1, YY1	
<b>Response only when requested by command</b>									
ESC	N	1	no				After the 'ESC N S' command, the currently selected menu item is transmitted. no=0: no menu item is selected.		
ESC	B	2	no	value				After the 'ESC B S n1' command, the current value of the bar is transmitted with the num nr.	
ESC	X	2	code	value				After the 'ESC A X' command, the current status of the touch switch is transmitted with c (the return code). value = 0 or 1	
ESC	G	2	no	code				After the 'ESC A G nR' command, the code of the active touch switch in the radio group sent.	
ESC	V	num	String...			After the 'ESC S V' command, the version of the edip firmware is transmitted as a string (e.g. "ea edip320-8 v1.0 rev.a tp+")			
ESC	I	num	X Pixel, Y Pixel, Version, Touch info, CRC-ROM, CRC-ROM target DF in KB, CRC-DF, CRC-DF target, DF num			num = 21 after the 'ESC S I' command, internal information is sent by eDIP (16-Bit integ values LO-HI Byte) Version: LO-Byte = version number Software; HI-Byte = Hardware revision letter touch info: LO-Byte = '- +' X direction detected; HI-Byte = '- +' Y direction detected DF num: number of user bytes in data flash memory (3 Bytes: LO-, MID- HI-By			
<b>Responses without length specification (num)</b>									
ESC	U	L	xx1	yy1	image data... (BH7 FORMAT)		after the 'ESC UH....' command, a hard copy is sent in BH7 Format. xx1,yy1 = Start coordinates of the hard copy (upper left corner)		

## USING THE SERIAL INTERFACE

The operating unit can be programmed by means of various integrated commands. Each command begins with ESCAPE followed by one or two command letters and then parameters. There are two ways to transmit commands:

### 1. ASCII mode

- The ESC character corresponds to the character '#' (hex: \$23, dec: 35).
- The command letters come directly after the '#' character.
- The parameters are transmitted as plain text (several ASCII characters) followed by a separating character (such as a comma ',') - also after the last parameter e.g.: #GD0,0,319,239,
- Strings (text) are written directly without quotation marks and concluded with CR (hex: \$0D) or LF (hex: \$0A).

### 2. Binary mode

- The escape character corresponds to the character ESC (hex: \$1B, dec: 27).
- The command letters are transmitted directly.
- The coordinates xx and yy are transmitted as 16-bit binary values (first the LOW byte and then the HIGH byte).
- All the other parameters are transmitted as 8-bit binary values (1 byte).
- Strings (text) are concluded with CR (hex: \$0D) or LF (hex: \$0A) or NUL (hex: \$00).

No separating characters, such as spaces or commas, may be used in binary mode.

The commands require **no final byte**, such as a carriage return (apart from the string \$00).

**TOP VIEW AFTER 180° ROTATION**

The best way to view the EA eDIP320 is diagonally from below (bottom view, 6 o'clock).

The eDIP320 can be **installed rotated by 180°** to get the top view (12 o'clock).

To correct the contents of the screen, three solder straps (JS, JS1 and JC) have to be resoldered.

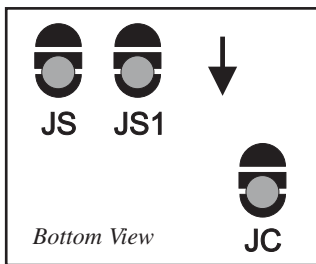

**Important:** Always place all solder straps in the same position and desolder them cleanly. Short circuits destroy the eDIP320-8.

If an eDIP320-8 with a touch panel is used, the touch interpretation must also be changed with the command 'ESC AO 1'.

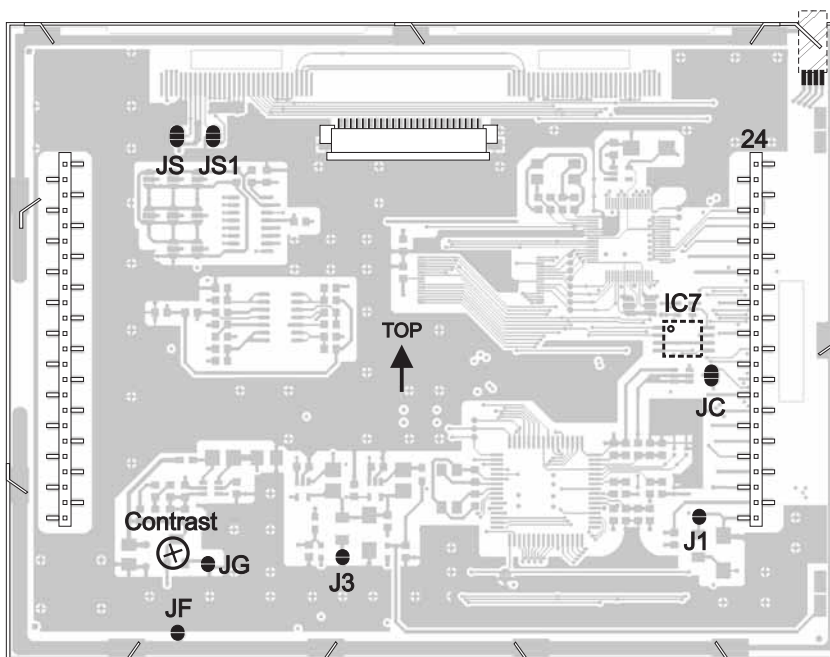
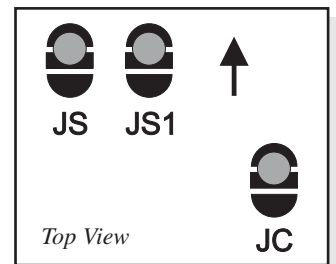
**POWER-DOWN MODE**

To save energy (battery operation), you can activate power-down mode by means of the command 'ESC PD n1' (see page 15 below). The LED illumination is switched off, and the contents of the display become invisible although they are still there.

In power-down mode including suppressor diodes, the eDIP20 typically requires 150  $\mu$ A.

Thanks to the integrated suppressor diodes, however, the shunt current can also be 1000  $\mu$ A and more.

The suppressor diodes can be deactivated by opening the solder straps J1 and J3. Then power-down current of typically 20  $\mu$ A is reached.

**Important:** When the solder straps J1 and J3 are open, it is essential that the polarity of the display is correct at all the time: VDD, GND (pin 1 + 2). Even very brief polarity reversal or overvoltage can damage the display immediately and irreparably.

The eDIP320 can be woken from power-down mode by a level of L at pin 13 (WUP), when the screen is touched or through the I2C address.

## MACRO PROGRAMMING

Single or multiple command sequences can be grouped together in macros and stored in the data flash memory. You can then start them by using the *Run macro* commands. There are different types of macro (compiler directive marked in green letters):

### Normal macro (0 to 255) Makro:

These are started by means of an 'ESC MN xx' command via the serial interface or from another macro. A series of macros occurring one after the other can be called cyclically (movie, hourglass, multi-page help text). These automatic macros continue to be processed until either a command is received via the interface or a touch macro with a corresponding return code is activated. These macros are also called by macro processes at defined intervals. Macro processes are not interrupted when commands are received from the interface or when touch macros are triggered.

### Touch macro (1 to 255) TouchMakro:

Started when you touch/release a touch field (only in versions with a touch panel - TP) or issue an 'ESC MT xx' command.

### Menu macro (1 to 255) MenuMakro:

Started when you choose a menu item or issue an 'ESC MM xx' command.

### Power-on macro PowerOnMakro:

Started after power-on. You can switch off the cursor and define an opening screen, for example.

### Reset macro ResetMakro:

Started after an external reset (low level at pin 5).

### Watchdog macro WatchdogMakro:

Started after a fault/error (e.g. failure).

### Brown-out macro BrownoutMakro:

Started after a voltage drop under 3V.

### WakeUpPin macro WakeUpPinMakro:

Started after waking from power-down mode at pin 13 (WUP).

### WakeUpTouch macro WakeUpTouchMakro:

Start after waking from power-down mode by touch contact (WUP).

### WakeUpI<sup>2</sup>C macro WakeUpI<sup>2</sup>CMakro:

Started from power-down mode via the I<sup>2</sup>C bus.

**Important:** If a continuous loop is programmed in a power-on, reset, watchdog or brown-out macro, the display can no longer be addressed. In this case, the execution of the power-on macro must be suppressed. You do this by wiring WUP (power-off: connect pin 13 (WUP) to GND; power-on: open pin 13 (WUP) again).

## CREATING INDIVIDUAL MACROS AND IMAGES

To create your own macros, you need the following:

- To connect the display to the PC, you need the EA 9778-1USB USB programmer, which is available as an accessory, or a self-built adapter with a MAX232 level converter (see the application example below).
- ELECTRONIC ASSEMBLY LCD-Tools<sup>\*)</sup>, which contains a kit editor, kit compiler and examples and fonts (for Windows PCs)
- A PC with an USB or serial COM interface

To define a sequence of commands as a macro, all the commands are written to a file on the PC (e.g. DEMO.KMC). You specify which character sets are to be integrated and which command sequences are to be in which macros.

If the macros are defined using the kit editor, you start the eDIP320 compiler using F5. This creates a file called DEMO.DF. If an EA 9778-1USB programmer is also connected or the display is connected to the PC via a MAX232, this file is automatically burned in the display's data flash memory. The eDIP320 compiler recognizes the display regardless of whether the small protocol is switched on. You will find a detailed description of the programming of the macros together with examples in the ELECTRONIC ASSEMBLY LCD-Tools<sup>\*)</sup> help system.

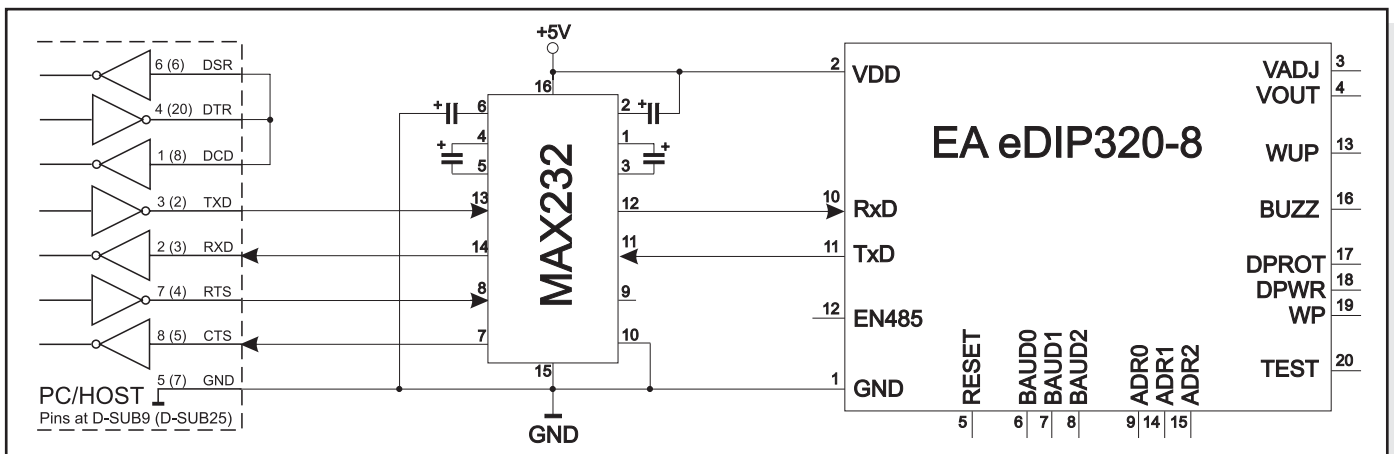

Adaptor for interfacing to a PC

<sup>\*)</sup> full version is free available on web at <http://www.lcd-module.com/products/touch.html>

## STORING IMAGES IN THE DATA FLASH MEMORY

To reduce the transmission times of the interface or to save storage space in the processor system, up to 256 images can be stored in the internal data flash memory (80 kB) using the "PICTURE" compiler directive. They can be called using the "ESC U I" command or from within a macro.

All images in the Windows BMP format (monochrome images only) can be used. They can be created and edited using widely available software such as Windows Paint or Photoshop or the bitmap editor shipped with the product.

You can use the "PICTURE" compiler directive to integrate two monochrome BMPs of equal size for touch keys, screen masks or flashing images.

```
PICTURE: 1 <BITMAP1.BMP>
PICTURE: 2 <BITMAP2.BMP>, <MASK2.BMP>
PICTURE: 3 <BITMAP3.BMP>, <BLINK3.BMP>
PICTURE: 4 <TOUCH.BMP>, <TOUCHPRESSED.BMP>
```

## MACRO PAGES (MULTILINGUAL CAPABILITY)

There are 16 complete macro sets available in each case for the normal, touch and menu macros as well as the internal images. By simply switching the active macro page (ESC M K n1), for example, up to 16 different languages can thus be supported.

If a macro/picture is defined in the kit editor, a page number can be specified in square brackets after the macro/picture number.

If a macro/image is not defined in the currently set page [1] to [15], this macro/picture is automatically taken from page [0]. Thus, not all macros and images have to be stored separately for each language when they are identical in each language.

```
PICTURE: 100[0] <SAUSAGE.BMP>
PICTURE: 100[1] <BEER.BMP>
PICTURE: 100[2] <WINE.BMP>

MACRO: 2[0] ; SAME AS "MACRO: 0"
#ZV REPLACE
#ZL 25, 0 „DEUTSCH “
#UI 0, 20, 100

MACRO: 2[1] ; ENGLISH
#ZV REPLACE
#ZL 25, 0 „ENGLISH “
#UI 0, 20, 100

MACRO: 2[2] ; FRENCH
#ZV REPLACE
#ZL 25, 0 „FRANCAISE“
#UI 0, 20, 100
```

## WRITE PROTECTION FOR MACRO PROGRAMMING AND FONTS

A LO level at pin 19 (WP) prevents the macros, images and fonts in the data flash memory from being overwritten inadvertently (so it is highly recommended!).

## ADDING MEMORY

The internal data flash memory is 80 kB. That means there is generally enough space for a large number of icons and macros. However, if a very large number of images (full images, in particular) or several large character sets are to be stored, it may be necessary to add more memory (max. 8192 kB). This can be done by directly soldering a data flash memory from the AT45DBxxxD-SU series onto the eDIP320 (see page 18 IC7).

For example: AT45DB041D-SU = 512 kB, AT45DB081D-SU = 1024 kB or AT45DB161D-SU = 2048 kB.

# ADAPTOR BOARD FOR EA eDIP320-8



## TECHNICAL DATA

- \* **EA 9778-1USB**
- \* PROGRAMMING BOARD FOR USB
- \* INCLUDING USB CABLE
- \* VERY EASY TO USE, NO POWER SUPPLY REQUIRED
- \* REQUIRES USB DRIVER, WHICH IS INCLUDED
  
- \* **EA 9778-1RS232**
- \* RS-232 INTERFACE BOARD WITH  $\pm 12V$  LEVELS AT RXD AND TXD
- \* INCLUDING EA KV24-9B CABLE WITH 9-PIN D-SUB CONNECTOR
- \* REQUIRES EXTERNAL SUPPLY +5V/TYPICALLY 270 mA
- \* OPTIONAL SUPPLY 9 TO 35VDC INSTEAD OF 5V (EA OPT-9/35V)
  
- \* **EA 9778-1RS485**
- \* INTERFACE BOARD FOR RS-485 2-WIRE CONNECTION
- \* REQUIRES EXTERNAL SUPPLY +5V/TYPICALLY 300 mA
- \* OPTIONAL SUPPLY 9 TO 35VDC INSTEAD OF 5V (EA OPT-9/35V)

## ORDER DESIGNATION

STARTER KIT, BLUE (1x EA eDIP320B-8LWTP + EA 9778-1USB)  
STARTER KIT, B/W (1x EA eDIP320J-8LWTP + EA 9778-1USB)  
PROGRAMMING BOARD INCLUDING USB CABLE AND CD FOR PC  
RS-232 BOARD WITH  $\pm 12V$  LEVELS AT RXD AND TXD  
INTERFACE BOARD FOR RS-485 2-WIRE CONNECTION  
SUPPLY 9 TO 35VDC INSTEAD OF 5V (9778-1RS232,-1RS485 ONLY)

**EA STARTEDIP320B**  
**EA STARTEDIP320J**  
**EA 9778-1USB**  
**EA 9778-1RS232**  
**EA 9778-1RS485**  
**EA OPT-9/35V**

### MOUNTING BEZEL EA 0FP321-8SW

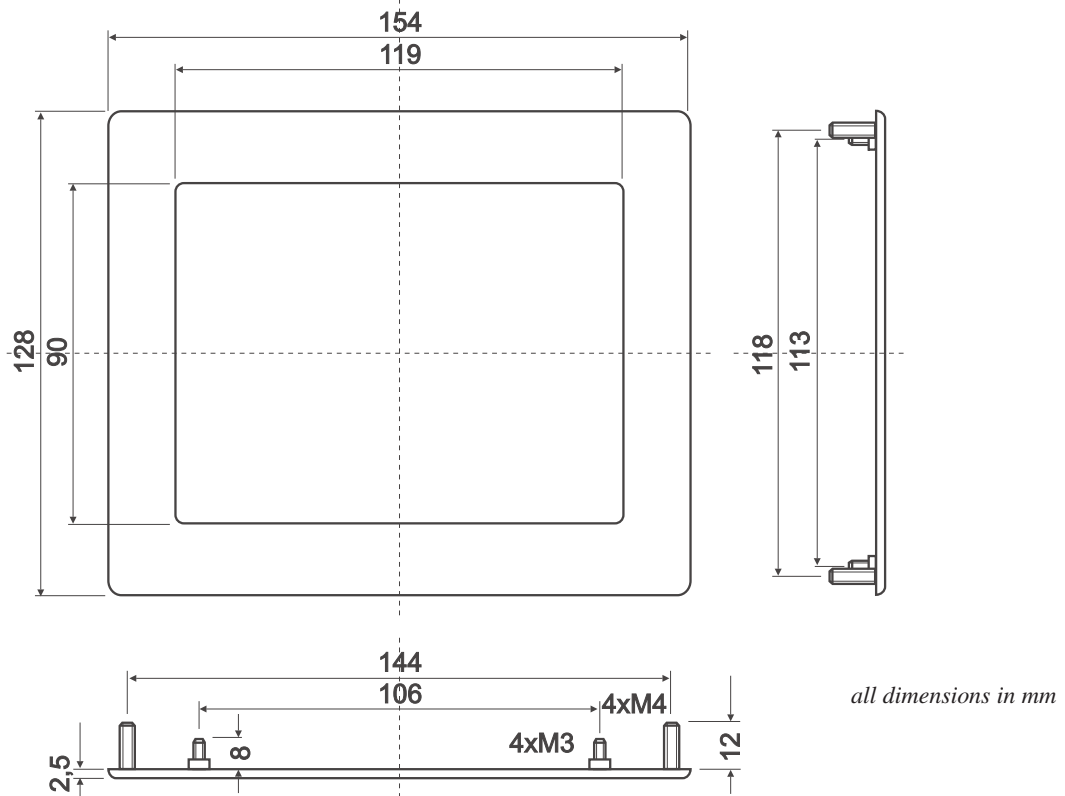

### NOTES ON HANDLING AND OPERATION

- The module can be destroyed by polarity reversal or overvoltage of the power supply; overvoltage, reverse polarity or static discharge at the inputs; or short-circuiting of the outputs.
- It is essential that the power supply is switched off before the module is disconnected. All inputs must also be deenergized.
- The display and touch screen are made of plastic and must not come into contact with hard objects. The surfaces can be cleaned using a soft cloth without solvents.
- The module is designed exclusively for use in buildings. Additional measures have to be taken if it is to be used outdoors. The maximum temperature range of -20 to +70°C must not be exceeded. If used in a damp environment, the module may malfunction or fail. The display must be protected from direct sunshine.



## DIMENSIONS

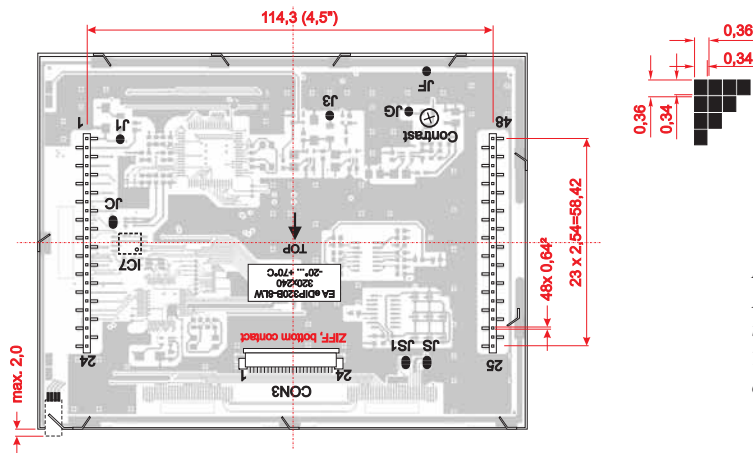
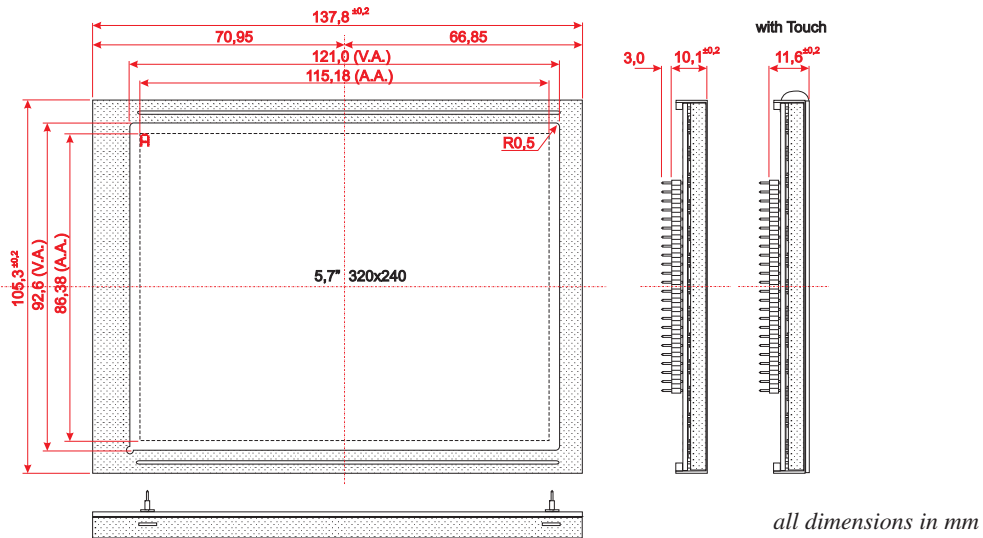

Note:  
 LC displays are generally not suited to wave or reflow soldering.  
 Temperatures of over 90°C can cause lasting damage.

## DIMENSIONS WITH ASSEMBLY BRACKETS

The mounting brackets are included with the product.

